

Functioning of Circuits Connecting Thalamus and Cortex

S. Murray Sherman*¹

ABSTRACT

Glutamatergic pathways in thalamus and cortex are divided into two distinct classes: **driver**, which carries the main information between cells, and **modulator**, which modifies how driver inputs function. Identifying driver inputs helps to reveal functional computational circuits, and one set of such circuits identified by this approach are **cortico-thalamo-cortical** (or transthalamic corticocortical) circuits. This, in turn, leads to the conclusion that there are two types of thalamic relay: first order nuclei (such as the lateral geniculate nucleus) that relay driver input from a subcortical source (i.e., retina), and higher order nuclei (such as the pulvinar) which are involved in these transthalamic pathways by relaying driver input from layer 5 of one cortical area to another. This thalamic division is also seen in other sensory pathways and beyond these so that most of thalamus by volume consists of higher-order relays. Many, and perhaps all, direct driver connections between cortical areas are paralleled by an indirect cortico-thalamo-cortical (transthalamic) driver route involving higher order thalamic relays. Such thalamic relays represent a heretofore unappreciated role in cortical functioning, and this assessment challenges and extends conventional views regarding both the role of thalamus and mechanisms of corticocortical communication. Finally, many and perhaps the vast majority of driver inputs relayed through thalamus arrive via branching axons, with extrathalamic targets often being subcortical motor centers. This raises the possibility that inputs relayed by thalamus to cortex also serve as efference copies, and this may represent an important feature of information relayed up the cortical hierarchy via transthalamic circuits. © 2017 American Physiological Society. *Compr Physiol* 7:713-739, 2017.

Introduction

The conventional, textbook view of thalamocortical interactions needs a drastic makeover. That view goes something like this. Information from the periphery is relayed in a rather machine-like manner through certain thalamic nuclei to cortex. That information is then processed entirely within cortex via various intracortical pathways until executive areas are reached, from which outputs to brainstem or spinal sites are sent to affect behavior. This sensorimotor processing that occurs within cortex has no significant thalamic involvement, and thus the role of thalamus is limited to relaying peripheral information to cortex. In other words, except for the few thalamic nuclei that relay peripheral information to cortex, the rest of thalamus, which is the large majority by volume, has little to do.

The shortcomings of this conventional view are challenged here on several grounds. One is the notion that the thalamus acts as a simple relay; instead, its complex circuitry serves to gate and otherwise control the flow of information to cortex. By gating is meant the fact that relay cells receive strong inhibitory GABAergic inputs from local and external sources, and if these inputs are very active, the gate is shut (i.e., there is no relay to cortex), if the inputs are silent, the gate is open, and if the inputs are moderately active, the gate is partially open; by other control is meant the ability of

modulatory inputs to affect the synaptic gain of the input to be relayed or to affect the response mode, burst or tonic, of relay cells (details of these gating and control effects below). Another is that the idea that cortical processing of information has little or no role for thalamus, because much recent data shows that many or most of those thalamic nuclei not involved in the initial relay of information to cortex play a vital role in further cortical functioning. What that role (or roles) may be is still unclear, but several hypotheses are presented below.

We begin with an account of the cell and circuit properties of thalamus and how these properties affect the relay of information to cortex. We then consider relationships between thalamus and cortex in both directions. We end with speculations about aspects of the information actually relayed through thalamus to cortex. The result that is offered here is a theoretical framework for thalamocortical interactions that differs markedly from the textbook view.

*Correspondence to msherman@bsd.uchicago.edu

¹Department of Neurobiology, University of Chicago, Chicago, Illinois, USA

Published online, April 2017 (comprehensivephysiology.com)

DOI: 10.1002/cphy.c160032

Copyright © American Physiological Society.

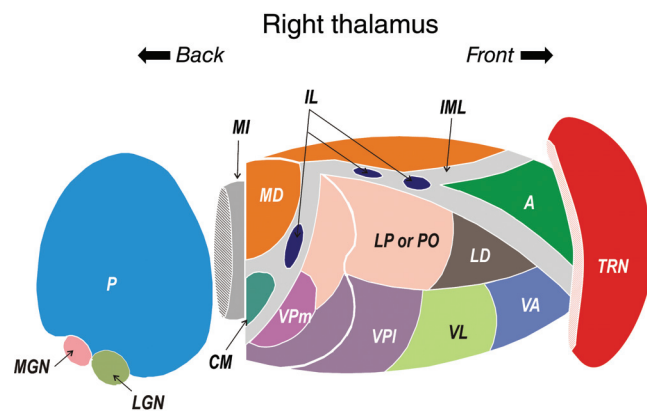

Figure 1 Schematic three-dimensional view of right thalamus with many of its major nuclei. A cut is placed in the posterior part to reveal a representative cross-section. To prevent obscuring the dorsal thalamus, only the rostral tip of the TRN is shown. *Abbreviations:* A, anterior nucleus; CM, centromedian nucleus; IL, intralaminar nuclei; IML, internal medullary lamina; LD, lateral dorsal nucleus; LP, lateral posterior nucleus; LGN, lateral geniculate nucleus; MGN, medial geniculate nucleus; MD, mediodorsal nucleus; MI, midline nuclei; P, pulvinar; PO, posterior nucleus; TRN, thalamic reticular nucleus; VA, ventral anterior nucleus; VPI, ventral posterolateral nucleus; VPm, ventral posteromedial nucleus. See Jones (75) for details of connectivity of these nuclei. Redrawn, with permission, from (149).

Thalamus

Overview

The thalamus is a **paired structure** that sits **near the middle of the brain**; each member of the pair is roughly the size of a walnut. Figure 1 shows a schema of the various parts of the thalamus. It can be divided into dorsal and ventral divisions related to embryonic origin. The dorsal division is comprised of the nuclei, or cell groups, containing the relay cells that project to cortex. Most of the ventral division is the thalamic reticular nucleus, which project onto relay cells of the dorsal thalamus; the remainder is the ventral part of the lateral geniculate nucleus. Neither reticular neurons nor neurons of the ventral part of the lateral geniculate nucleus project to cortex.

Most of the relay nuclei topographically innervate one or a few areas of cortex, targeting the middle layers, but some project diffusely to upper cortical layers, including layer 1; the former have been referred to as “core,” and the latter, as “matrix” (72). Rather little is known of the functioning of matrix thalamocortical circuits, and it is not considered further below [for further details of matrix thalamocortical features, see (71, 73, 74, 76, 119, 175, 176)]. Unless otherwise specified, reference below to “thalamus” refers to the dorsal division of thalamus and core nuclei, and “lateral geniculate nucleus” refers to the dorsal part, which projects to cortex (the ventral part of the lateral geniculate nucleus does not). It appears that every area of cortex receives a thalamic input, and with few exceptions, thalamus represents the only input to cortex from subcortical sources. Thus, it is generally the case that if information is not successfully relayed through

thalamus, it does not reach cortex and is neither perceived nor is a factor in cortical processing.

The complexity of thalamic cell and circuit properties belies any notion that it is a simple, machine-like relay. The idea of a simple relay arose from the heavy reliance of the receptive field approach to investigate sensory systems, and the visual system stands as a good example [reviewed in (2, 65)]. Such studies of the retina showed that receptive fields become more complicated as synaptic levels are ascended, from photoreceptors to bipolar cells to ganglion cells. Likewise, receptive fields become more elaborated as processing transpires within visual cortex. Thus, retina and cortex are organized to elaborate receptive field properties as synaptic hierarchies are ascended. Such elaboration is thought to be the basis for the brain’s ability to reconstruct the sensory environment. The one exception to this is the synapse between retinal axons and relay cells of the thalamic lateral geniculate nucleus: that is, the center/surround properties of retinal axons are nearly identical to those of the relay cells (2, 65). Thus, unlike retinal and cortical circuitry, thalamic circuitry seemed to do little except relay information without much change or elaboration.

We now know that this is wrong, and in fact the case can be made that, while other structures perform the same general function (i.e., elaborate receptive fields), the thalamus does something unique, which is to gate or control the flow of information to cortex, among other more subtle functions. Most of the abovementioned receptive field studies were done in anesthetized animals, and, ironically, the anesthetics used tend to block transmitter systems that, in the behaving animal, serve to affect how relay cells respond to and pass on information to cortex.

It now seems clear that **the thalamus represents a bottleneck for the transfer of information to cortex**, and as such, **presents an efficient site to control information flow**. In other words, to upregulate or downregulate a signal, as occurs for instance during attentional demands, the numbers of cells and synapses that must be affected are orders of magnitude less in thalamus than in cortex for the equivalent effect, and there is ample evidence that thalamus is involved in such modulation of signal effectiveness (16, 38, 100, 135, 183).

Although a full understanding of the gating properties of thalamus remains to be provided, insights into the process begin with an understanding of the cell and circuit properties described in the following sections.

Thalamic circuit properties

Cell types. Figure 2 shows the three basic cell types—relay cells, interneurons, and reticular cells—that are involved in thalamic processing, and the schematic circuit diagram of Figure 3A shows how they relate to one another. Each of these cell types contains various sub-types, but, except for the relay cells, these are not further considered here [for additional details, see (148)].

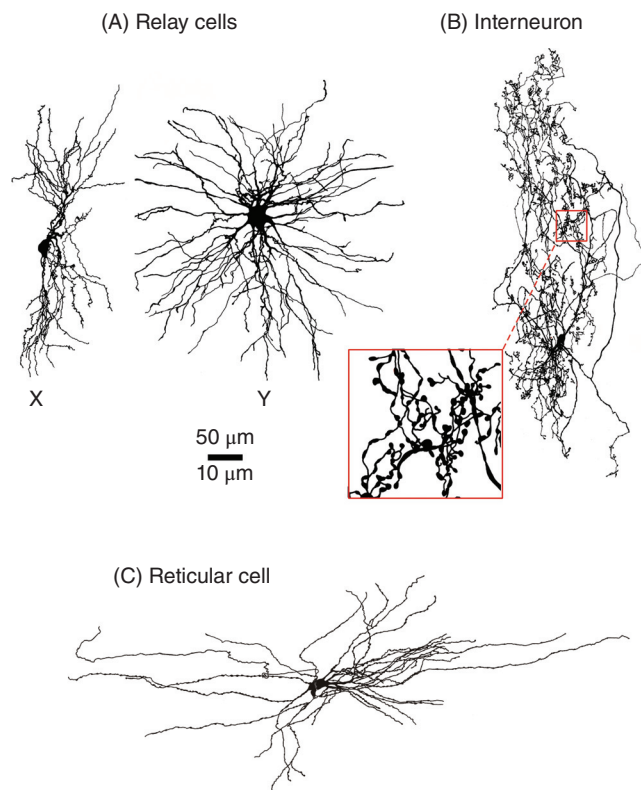

Figure 2 Reconstruction of representative thalamic cell types from the lateral geniculate nucleus of the cat based on intracellular dye filling of individual, physiologically identified neurons. (A) Relay X and Y cell. (B) Interneuron. The inset shows the presynaptic bouton terminals emanating from dendrites. (C) Cell of the thalamic reticular nucleus. The larger scale applies to the inset for the interneuron. A and B, with permission, from [46]; and C, with permission, from [166].

Relay cells are glutamatergic (i.e., use glutamate as a neurotransmitter). They receive glutamatergic input from a main information source (referred to below as the “driver” input) and relay this to cortex. On its way to cortex, the axon passes through the thalamic reticular nucleus, at which point the axon produces a branch that innervates reticular cells. Relay cells represent roughly $\frac{3}{4}$ of the neurons in dorsal thalamus, the remainder being interneurons. An odd exception is the thalamus of the rat and mouse, where the lateral geniculate nucleus contains appropriate numbers of interneurons, but the rest of thalamus contains almost no interneurons. This is not a rodent feature, since other rodents (e.g., guinea pigs, hamsters, squirrels, etc.) contain numerous interneurons throughout (6). This remains an enigma.

Relay cells are a heterogeneous group, and this is best documented for the lateral geniculate nucleus of cats and monkeys, where at least three different classes have been identified for each, called W, X, and Y for cats, and koniocellular (K), parvocellular (P), and magnocellular (M) for monkeys, and their main differences are seen in their receptive field properties, although anatomical differences also exist (140, 188). Examples of an X and Y cell are shown in Figure 2A.

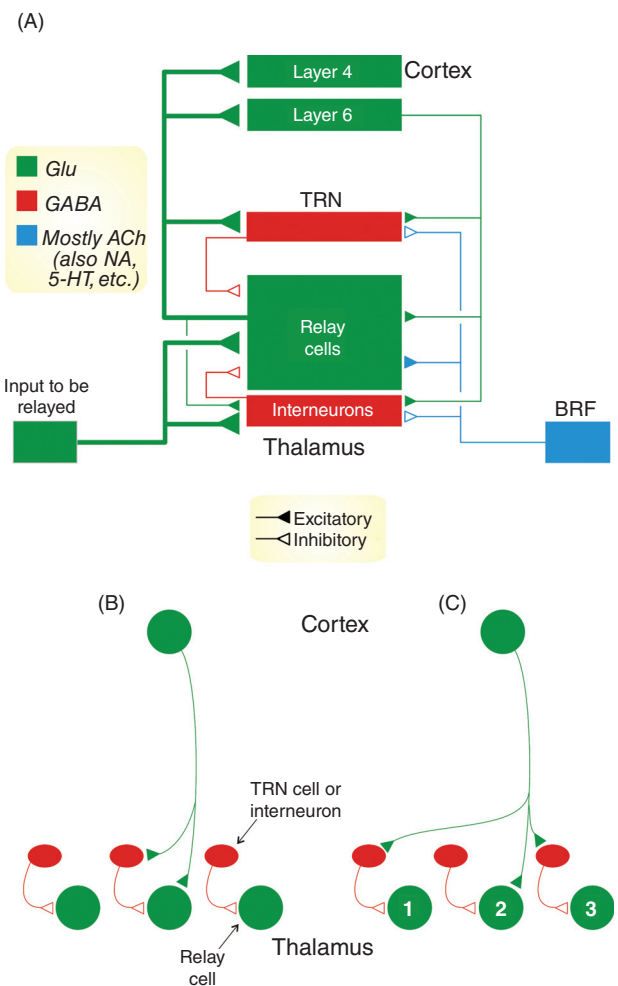

Figure 3 (A) Schematic and simplified view of thalamic circuitry. The various inputs to the different thalamic cell types are displayed, and the excitatory or inhibitory postsynaptic effect. (B and C) Schematic view of different possible circuits involving layer 6 corticothalamic input to reticular cells, interneurons, and relay cells. See text for details. Abbreviations: 5-HT, serotonin; ACh, acetylcholine; BRF, brainstem reticular formation; GABA, γ -aminobutyric acid; Glu, glutamate; NA, norepinephrine; TRN, thalamic reticular nucleus.

Interneurons are GABAergic (i.e., use GABA, or γ -aminobutyric acid, as a neurotransmitter), and as their name implies, their projections are limited locally to their dorsal thalamic site of origin. They provide inhibitory input to relay cells. An interesting aspect of these cells is that they produce synaptic outputs both conventionally via their axons and unconventionally via their dendrites. Furthermore, their dendritic outputs enter into complex synaptic triadic relationships with relay cells, relationships that are more fully described later (142, 148). How much heterogeneity exists among interneurons is presently unknown.

Cells of the thalamic reticular nucleus are also GABAergic, and like interneurons, their main targets are relay cells. Thus, relay cells receive two separate local GABAergic inputs. Other than the observation that interneurons innervate relay cells on more proximal dendritic locations than do reticular cells (148), the significance of these different GABAergic

inputs is unclear. As is the case with interneurons, heterogeneity among reticular cells is a yet a largely unexplored issue.

Overview of thalamic circuitry. Figure 3A shows a simplified schema of thalamic circuitry. Whereas there is variation among thalamic nuclei and species, to a first approximation, this schema serves as a reasonable sketch of relevant connections. The main difference between thalamic nuclei is the source of the input to be relayed, which, as noted above, is referred to as the driver input. The driver input is retina for the lateral geniculate nucleus, but for the ventral posterior nucleus (the primary somatosensory relay), it is the medial lemniscuses, etc.

In addition to the connections among the three cell types just described above are two main sources of extrinsic input to thalamic circuitry. One arises from scattered cell groups in the brainstem, also known as the brainstem reticular formation. Numerous terms for these cell groups exist, including pedunculo-pontine nuclei, parabrachial region, etc. (148). These provide a mostly cholinergic input to thalamic cells, but other classical modulatory systems, including noradrenergic, serotonergic, etc., also exist. The other main extrinsic input is glutamatergic and arises from layer 6 of cortex. This is regarded as a reciprocal feedback projection, because it innervates the same thalamic relay cells that topographically innervate its area of cortex. Reciprocal feedback is distinguished from the less specified type of feedback: the former reflect reciprocal inputs from cell groups at different hierarchical levels, whereas the latter implies feedback that may or may not be reciprocal, such as from a higher cortical area to a lower one in the absence of a projection from the lower to higher area.

The cholinergic input does a neat trick: generally, it excites relay cells while it inhibits reticular cells and interneurons. (“Generally” is used here, because, as noted below, a distinct minority of relay cells in some thalamic nuclei is inhibited by ACh; see ref. 171.) It accomplishes this by activating different postsynaptic muscarinic receptors on each cell type, mostly M1 on relay cells, which leads to closing of K^+ channels to depolarize the cell, and M2 on the GABAergic cells, which leads to opening of K^+ channels to hyperpolarize the cell. As a result, activation of this input excites relay cell both by direct excitation and indirect disinhibition.

The effect of cortical input on relay cells is more complicated to address, because it depends critically on details of the connectivity of the thalamic neurons. This is shown in Figure 3B and C, which depicts two configurations among other possibilities. Figure 3B represents a circuit that both directly excites relay cells and indirectly inhibits them via feedforward inhibitory circuit, and so the overall effect of cortical activation via this scheme would appear to have little net effect if conjoint activation of reasonably balanced excitatory and inhibitory inputs occur, leading to little effect on the relay cell’s membrane potential. However, it has been suggested that such conjoint activation would reduce the cell’s input resistance through activation of synaptic conductances, and this would make the cell less responsive to other inputs

(25). In this manner, the circuit of Figure 3B could help control relay cell excitability. Figure 3C offers a different picture. Here, activation of a cortical input excites some relay cells (e.g., cell 2) and inhibits others (e.g., cells 1 and 3). Evidence for both circuits in Figure 3B and C exists (85).

Relay cells project most densely to middle layers of cortex, predominantly layer 4, but other layers are also targeted (148).

Thalamic triads. Information-bearing inputs (such as retinal inputs or medial lemniscal to the lateral geniculate or ventral posterior nuclei, respectively) onto relay cells can be either simple synapses onto dendrites or occur in triadic arrangements within complex synaptic zones known as glomeruli (61, 142, 184). This is schematically depicted for the lateral geniculate nucleus in Figure 4A, and as the term suggests, the triad involves three synapses. The main form involves a retinal synapse from a single terminal that contacts both the dendritic terminal of an interneuron as well as a relay cell dendrite, and a synapse from the same interneuron dendritic terminal contacts the same relay cell dendrite. Thus, the interneuronal terminal is both presynaptic and postsynaptic. Another type of triad involves cholinergic inputs from the brainstem reticular formation: like the retinal axon, the cholinergic axon synapses onto both an interneuron terminal and relay cell dendrite (but via different terminals), and the interneuron terminal contacts the same relay cell dendrite.

All of the above triadic synapses occur with a glomerulus, and an unusual feature of this arrangement is that, unlike typical synapses elsewhere that are each encased within a glial sheath, those in glomeruli are not so encased; instead, the whole complex is surrounded by glial membranes. The functional significance of this is unclear, but to the extent that glial sheaths control transmitter availability [e.g., (3, 118)], such a process would be absent in glomeruli. A final point is that synapses from interneuronal axons are also often found in glomeruli, but these make conventional, simple synapses, unlike their dendritic counterparts.

The functioning of the triad and glomerulus remains mostly a matter of conjecture, but recent studies of triads in the lateral geniculate nucleus, particularly of the postsynaptic receptors involved (Fig. 4A), provide some insights into this (30, 50, 142). In the case of the retinal triad, the retinal input to relay cell dendrite activates only ionotropic glutamate receptors, whereas that to the interneuron terminals activates metabotropic receptors as well. A full description of the differences between ionotropic and metabotropic receptors is beyond the scope of this review and can be found elsewhere (22, 112), but two main differences are relevant here. First, whereas low firing rates of an afferent input, even a single action potential, can activate ionotropic receptors, generally higher firing rates are needed to activate metabotropic receptors. Apparently, this results from metabotropic receptors being located further from transmitter release sites, perisynaptically, than are ionotropic receptors (97), and thus higher firing rates are needed to release sufficient transmitter to reach metabotropic receptors. However, as few as two

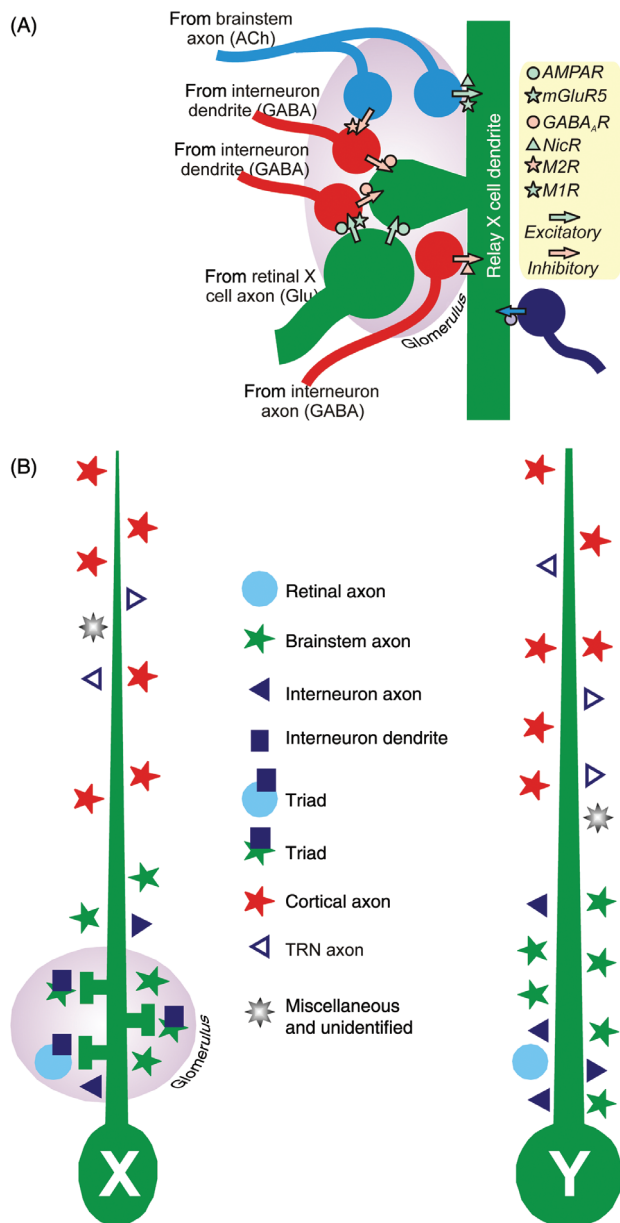

Figure 4 Schematic views of features of connectivity in the A layers of the cat's lateral geniculate nucleus. (A) Synaptic inputs in and near a glomerulus. Shown are the various synaptic contacts (arrows), whether they are inhibitory or excitatory, and the related postsynaptic receptors. The conventional triad includes the lower interneuronal dendritic terminal and involves three synapses (from the retinal terminal to the dendritic terminal, from the retinal terminal to an appendage of the X cell dendrite, and from the dendritic terminal to the same appendage). Another type of triad includes the upper interneuronal dendritic terminal and also involves three synapses: a branched (cholinergic) brainstem axon produces one synaptic terminal onto an X cell relay dendrite and another onto the dendritic terminal, and a third synapse is formed from the dendritic terminal onto the same relay cell dendrite. For simplicity, the NMDA receptor on the relay cell postsynaptic to the retinal input has been left off. (B) Synaptic inputs onto an X and a Y cell. For simplicity, only one, unbranched dendrite is shown. Synaptic types are shown in relative numbers. *Abbreviations:* ACh, acetylcholine; AMPAR, (R,S)- α -amino-3-hydroxy-5-methyl-4-isoxazolepropionic acid receptor; GABA, γ -aminobutyric acid; GABA_AR, type A receptor for GABA; Glu, glutamate; M1R and M2R, two types of muscarinic receptor; mGluR5, type 5 metabotropic glutamate receptor; NicR, nicotinic receptor. Redrawn, with permission, from (148).

action potentials separated by 100 ms or less in the afferent can begin to activate metabotropic glutamate receptors, although higher rates or more action potentials increasingly activate more of these receptors (178). Second, responses, such as excitatory or inhibitory postsynaptic potentials (EPSPs or IPSPs, respectively), are slower and somewhat delayed with the activation of metabotropic receptors: whereas activation of ionotropic receptors evokes postsynaptic responses within a millisecond or so and they last for 10 ms or so, that of metabotropic receptors is delayed by several milliseconds and lasts for hundreds of milliseconds to several seconds.

A suggestion of how these receptor properties affect the retinal triad are as follows (refer to Fig. 4A and (142)). When the retinal axon fires at low rates, EPSPs will be generated in both the relay cell dendrite and interneuron terminal via ionotropic glutamate receptors, and the latter EPSP could lead to small disynaptic IPSPs. As the retinal axon increases firing, the EPSPs (and disynaptic IPSPs) from activation of ionotropic receptors would grow accordingly, but also activation of the metabotropic receptors on the interneuron terminal come into play, and this, in turn, would lead to a further increase the amplitude of disynaptic IPSPs. In other words, the EPSP to IPSP ratio in the relay cell decreases with increasing activity on the retinal axon due to the increasing activation of metabotropic receptors on the interneuron terminal, and this means that the gain of retinogeniculate transmission is lowered. Furthermore, after cessation of firing in the retinal axon, the prolonged EPSPs in the interneuron terminal due to activation of metabotropic receptors there, which would outlast retinal activation by several seconds (50), would lead to prolonged IPSPs in the relay cell, meaning that the overall gain of retinogeniculate transmission remains reduced for that period. Retinal firing is monotonically related to the contrast of the visual stimulus, and so this process would mean that a sudden increase in contrast would reduce the gain of retinogeniculate transmission for several seconds and that this reduced gain would continue even after the contrast in the scene reduced to original levels. This is exactly what is needed for contrast gain control, which is an important property of the visual system, that, like other forms of adaptation (e.g., to brightness or motion), helps to adjust the sensitivity of visual neurons to the ambient levels of stimulation. Such adaptation to contrast is seen at all levels, from retina to the lateral geniculate nucleus to cortex (20, 155).

The function of the triad involving cholinergic input seems more straightforward (Fig. 4A; (30)). The direct projection onto relay cells activates nicotinic (ionotropic) and muscarinic (metabotropic M1) receptors, both of which lead to depolarization. The projection onto the interneuron terminal suppresses GABA release there, presumably by activating different muscarinic (metabotropic M2) receptors, and this would also have the effect of depolarizing the relay cell via disinhibition. Thus, overall, activation of this input would depolarize relay cells, and if the input were vigorous enough to activate the muscarinic receptors, the depolarization would be long lasting.

Detailed circuitry of X and Y cells in the cat. The most detailed thalamic circuitry has been worked out for the X and Y pathways in the cat, which remains the most comprehensive example of thalamic circuitry. Figure 4B shows the distribution of various inputs to relay X and Y cells (41,42,168,184). In both cases, virtually all inputs are onto dendrites with practically none onto the cell bodies. Of the synaptic inputs to these cells, roughly 5% derive from retina, roughly 30% each from local GABAergic inputs [i.e., interneurons and thalamic reticular nucleus (TRN) cells], the brainstem reticular formation, and layer 6 of visual cortex, and 5% remain unidentified as to source. Furthermore, these inputs demonstrate considerable spatial specificity in their dendritic termination sites: cortical and TRN inputs innervate distal dendrites, whereas retinal, interneuronal, and brainstem reticular inputs innervate proximal dendrites.

Where X and Y cells differ in this regard is in the nature of their retinal inputs. For Y cells, retinal synapses mostly are straightforward axodendritic contacts. However, as schematically depicted in Figure 4B, X cells are associated with the glomeruli and triads described above (33,60,184). One prediction of this difference is that geniculate X cells should

show more evidence of control of contrast gain than do Y cells.

It should be noted that glomeruli and triads are a regular feature of thalamic circuitry and is not limited to the lateral geniculate nucleus (148). Because triads and glomeruli are associated with interneurons, and because rats and mice have few interneurons outside of the lateral geniculate nucleus (6), triads and glomeruli are rare in these species outside of the lateral geniculate nucleus. Whether, as in the lateral geniculate nucleus, there are relay cell classes that can be defined in the basis of whether or not they are associated with these structures remains to be determined.

Figure 5 offers another schematic view of the innervation of X and Y cells to complement that of Figure 4A. The added detail here concerns the nature of interneuron innervation. As noted, interneuron dendrites innervate mostly only X cells in glomeruli via triads. However, interneuron axons innervate both relay cell types, but of interest is the observation that the receptive field center/surround organization of the interneuron, which is reflected in the axonal output [see above and (142)], is the opposite of that of the target relay cell, meaning that interneurons with an on center innervate relay cells with

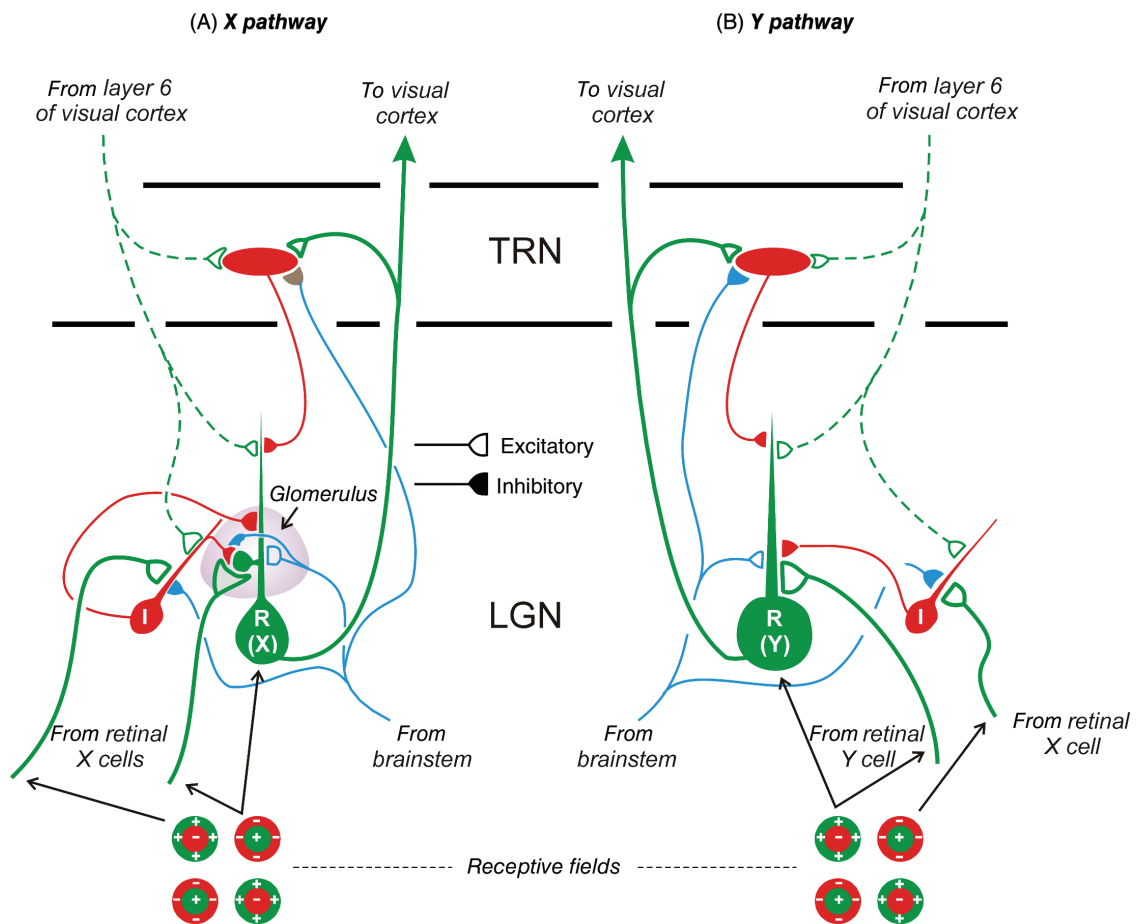

Figure 5 Overview of circuitry of LGN. (A and B) Detailed circuitry for X and Y relay cells of the LGN of the cat. The inhibitory inputs from axons of interneurons to relay cells is of the opposite center/surround type. For the center/surround receptive field icons, pluses refer to on areas, and minuses, to off areas. Redrawn, with permission, from (148). Abbreviations: I, interneuron; LGN, lateral geniculate nucleus; R, LGN relay cell; TRN, thalamic reticular nucleus.

an off center, and vice-versa (63). This provides an antagonistic (or a “push-pull”) organization so that, for instance, an on center relay cell will be excited by light in the center (or dark in the surround) and inhibited by dark in the center (or light in the surround).

Intrinsic cell properties and T type Ca^{2+} channels. Thalamic cells, like cells throughout the central nervous system, have a number of voltage- and time-gated ion conductances that affect neuronal responsiveness. The best-known examples are the Na^+ and K^+ conductances underlying the action potential. However, what sets thalamic cells apart from many other neurons elsewhere is the distribution and consequences of T type Ca^{2+} channels. When these T channels open, Ca^{2+} flows into the cell, representing a current known as I_T , and this leads to a large depolarizing spike of up to 25mV or more. Because the T channels are densely located in the membranes of the soma and dendrites, but not the axon, the Ca^{2+} spike propagates throughout the somadendritic membranes but not along the axon. [For a fuller account of T channels and other ionic properties, see (66, 94, 148)].

The voltage and time dependency of I_T involving these Ca^{2+} channels are as follows. I_T becomes inactivated following at least roughly 100 ms of roughly 5 to 10 mV of membrane depolarization from rest (rest being roughly -60 to 65 mV), and the inactivation is removed (or, I_T is de-inactivated) by an equivalent time and amplitude of relative hyperpolarization. Actually, the inactivation or de-inactivation of I_T is a complex function of voltage and time (68, 69, 153, 189). Thus, a stronger depolarization will inactivate I_T more quickly, and likewise a stronger hyperpolarization will deinactivate I_T more quickly.

If I_T is inactivated, a large enough depolarization (e.g., a sufficiently large EPSP) activates conventional action potentials with no role for I_T (Fig. 6A). This is called tonic firing and the cell is said to be in *tonic mode*. However, if I_T is deinactivated, it can then be activated by a sufficiently large depolarization, producing a large Ca^{2+} spike, which, in turn, produces a high-frequency burst of 2 to 10 action potentials (Fig. 6B). This is called burst firing and the cell is said to be in *burst mode*. Since the only signal reaching cortex is carried by conventional action potentials (the Ca^{2+} spike does not travel along the axon, because the requisite dense array of Ca^{2+} channels does not exist in axons), it follows that the signal during burst firing is quite different than that during tonic firing even though the activation depolarization (or afferent EPSP) is the same in both cases. This, in turn, means that the membrane voltage of the relay cell (i.e., whether I_T is inactivated or de-inactivated) plays an important role in the nature of the signal relayed to cortex.

For two reasons, the response during tonic firing more faithfully and linearly reflects the depolarizing input than is the case during burst firing. First, during tonic firing, action potentials are evoked as long as the depolarization remains above firing threshold. Because the properties of the T channel limit the rate of Ca^{2+} spiking to about 10 Hz, typically only a single burst is evoked in this mode, and so, unlike

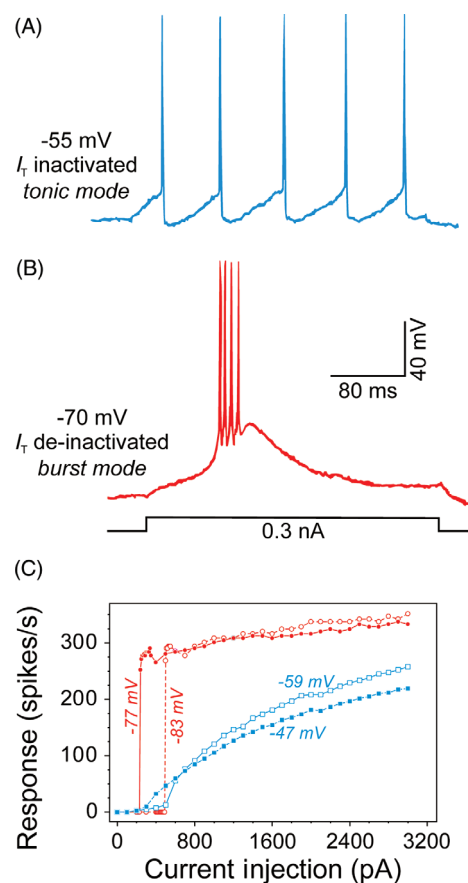

Figure 6 Burst and tonic firing based on I_T properties. Adapted, with permission, from (141). (A) I_T becomes inactivated following ≥ 100 ms of membrane depolarization relative to about -60 to 65 mV, and the inactivation is removed (or, I_T is deinactivated) by an equivalent time of relative hyperpolarization. (A) Tonic firing results when I_T is inactivated. (B) Burst firing results when I_T is deinactivated. (C) Input–output relationship for a single cell. The abscissa is the amplitude of the depolarizing current pulse and the ordinate is the firing frequency of the cell. The firing frequency was determined by the first six action potentials of the response, burst or tonic, because this cell normally exhibited six action potentials per burst in this experiment. The initial holding potentials are shown: -47 and -59 mV reflects tonic mode (blue points and curves), whereas -77 and -83 mV reflects burst mode (red points and curves).

tonic firing, the temporal properties of the response do not correlate well with that of the depolarizing input (Fig. 6A and B). Second, the number or rate of action potentials evoked during tonic firing correlate with the depolarizing input: the larger the depolarization, the greater the firing. This is not the case for burst firing. This is because the action potentials are generated not directly by the depolarizing EPSP input but rather by the Ca^{2+} spike, which is an all-or-none event; this, in turn, means that any depolarization above threshold for the Ca^{2+} spike evokes the same depolarizing spike and thus the same number of action potentials. Thus, whereas the input/output relationship is fairly linear during tonic firing, it is highly nonlinear, approximating a step function, during burst firing (Fig. 6C). This means that, during burst firing, there is much greater nonlinear distortion with respect to the original information in the signal sent to cortex.

This linearity difference clearly represents an advantage for tonic firing, but there is a different advantage to burst firing. Because of the properties of the thalamocortical synapse, namely that the synapse shows the quality of paired pulse depression [see below and (148)], the temporal properties of burst versus tonic firing mean that bursts much more strongly activate cortex than does tonic firing (93, 161, 162, 182). Much of this advantage is due to the fact that, to burst, a cell must be hyperpolarized for at least 100 ms or so, and this means it fires no action potentials during that period; this results in relief of synaptic depression so that when a burst is evoked, the initial EPSP in cortex has its maximal amplitude. In contrast, during tonic firing, the thalamocortical synapse is constantly depressed, leading to a smaller EPSP. Furthermore, the high frequency burst of spikes following the initial spike in the burst occur close enough in time for their evoked EPSPs to summate, further depolarizing target cortical cells and extending the ability of bursts to excite cortex compared to tonic firing.

These differences between burst and tonic firing have led to the following hypothesis. The linearity of tonic mode suggests that tonic firing is better for discrimination of signals, because tonic firing does not suffer from the nonlinear distortion of the signal caused by bursting. However, burst mode more strongly activates cortex; and this suggests that burst firing serves as a “wake-up call” to cortex, useful for detection by alerting cortex that something has changed in the environment, and after this occurs, the reciprocal feedback from layer 6 of the cortical area can switch firing to tonic mode to permit more faithful analysis of the new stimulus (141). Consistent with this view are the observations that bursting is more common during periods of inattention and that novel stimuli are effective in evoking bursts (116); reviewed in (148).

Drivers and Modulators

One of the first steps taken in analyzing a complex system is to identify the different component parts. For instance, an early step in understanding retinal organization was the identification of the different cell types involved: photoreceptors, bipolar cells, etc. Also important was the appreciation that each of these types could be further placed into subclasses, so that we have rods and several types of cones among photoreceptors and numerous distinct classes of retinal ganglion cell. Likewise, studies of cortical circuitry early on involved classifying the different cell types involved.

In a similar vein, a requirement for beginning to understand complex circuitry in the central nervous system is a classification of the different types of synaptic input that serve as the chief communication link between neurons. A top-level classification is based on the different transmitters employed by various inputs, and so we distinguish among glutamatergic, GABAergic, cholinergic, etc., inputs. However, like retinal ganglion cells, each of these can be further subdivided, and this an important feature of glutamatergic inputs in cortex and thalamus.

Classification of glutamatergic inputs

A common view is that transmitters alone provide a key to understanding the functional organization of circuits. That is, glutamatergic inputs are seen as providing the main information to be acted upon, and other inputs (GABAergic, cholinergic, noradrenergic, etc.) act as modulators to affect how the glutamatergic information is processed. Identifying the subset of inputs that are glutamatergic is the crucial step here, and once identified, these are given equal weight in terms of importance, meaning that numerically larger inputs are more important. However, analysis of circuits in thalamus and cortex has made clear that this classification is insufficient, because glutamatergic inputs there can be further subdivided into at least two classes, and only one appears to be the main vehicle for information handling.

Glutamatergic inputs to geniculate relay cells. The lateral geniculate nucleus offers a clear illustration of this classification issue in glutamatergic inputs, using as examples retinal input and that from layer 6 of cortex. Which of these represents the main information for relay by the lateral geniculate nucleus to visual cortex? One way to determine this is to consider receptive field properties of the constituent elements (2, 65), because how a cell responds to visual stimuli indicates the nature of the information transmitted to its postsynaptic targets. Figure 7 illustrates the main points here. Receptive fields of the retinal afferents have the classic center/surround configuration and are monocularly driven, whereas those of

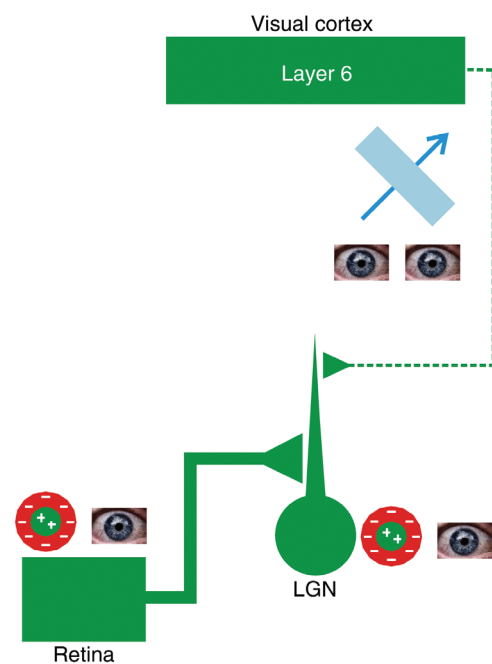

Figure 7 Different receptive field properties involved in responses of geniculate relay cells. Those of the retinal input display the classic center/surround structure, and these are monocularly represented. Those of the layer 6 cortical input have more complex features, including orientation and direction selectivity, and these are binocularly represented. Those of the geniculate cell have features much like those of its retinal input and unlike its cortical input.

the layer 6 inputs are much more complex, showing orientation and often direction selectivity, and they are binocularly driven. Receptive fields of the geniculate relay cells are monocularly driven with a center/surround configuration, very much like those of their retinal afferents and completely unlike those of their cortical afferents.

It is thus clear from this analysis that the retinal input carries the main information for geniculocortical relay, and we have called this input the *driver* input (146, 148). What, then, is the role of the cortical input? The suggestion, elaborated later, is that it acts as a *modulator*, much like the classic cholinergic, noradrenergic, etc., modulators, affecting the gain and other aspects of retinogeniculate transmission. The main point here is that, whereas both the retinal and cortical inputs are glutamatergic, they have quite different functions and should not be grouped together.

Drivers and modulators. Key to the classification is that a number of parameters have been found to distinguish the retinal (driver) and cortical (modulator) inputs to geniculate relay cells [reviewed in (148); see Figure 8]:

- retinal afferents activate only ionotropic receptors (α -amino-3-hydroxy-5-methyl-4-isoxazolepropionic acid, or AMPA, and N-methyl-D-aspartate, or NMDA), whereas cortical inputs in addition activate metabotropic glutamate receptors (Fig. 8A);
- retinal inputs innervate more proximal dendrites than do cortical inputs (Fig. 8A);
- retinal inputs are often found in glomeruli, whereas cortical inputs are not (Fig. 8A);
- retinal inputs show a depressing activation pattern indicative of a high probability (p) of transmitter release associated with each afferent action potential, whereas cortical inputs show a facilitating pattern indicative of a low p (Fig. 8B);
- retinal inputs evoke larger initial EPSPs than do cortical inputs (Fig. 8B);
- retinogeniculate EPSPs are activated in an all-or-none manner as stimulation parameters are increased, indicative of little convergence of inputs, whereas corticogeniculate EPSPs show a graded pattern of activation, suggesting considerable convergence (Fig. 8A and B);
- retinal inputs arrive via thick axons and large terminals in dense clusters, whereas cortical inputs arrive via thin axons with small terminals sparsely distributed (Fig. 8C); and
- finally, as noted above, retinal inputs provide only about 5% of the synapses onto relay cells, whereas cortical inputs produce 30% to 40% (Fig. 8A), the remainder arising from local GABAergic sources and the and brainstem reticular formation (Figs. 3A and 4B).

Table 1 Driver versus Modulator Properties

Driver	Modulator
Activates only ionotropic receptors	Activates ionotropic and metabotropic receptors
Synapses show paired-pulse depression (high p)*	Synapses show paired-pulse facilitation (low p)*
Large EPSPs	Small EPSPs
Minority of inputs	Majority of inputs
Less convergence onto target	More convergence onto target
Thick axons	Thin axons
Large terminals on proximal dendrites	Small terminals on distal dendrites

* p refers to the probability of transmitter release.

These differences between drivers and modulators are found generally in thalamus, although mainly only the sensory relays have been thoroughly tested so far. More interestingly, most (but not all) of these differences also apply to cortical circuitry (148), and those general to thalamus and cortex are summarized in Table 1. Figure 8D shows a three-dimensional scatterplot of three of the parameters from Table 1. Each data point here represents a single neuron for which a glutamatergic input was identified as driver or modulator (and both input types have been identified in some cells), and the color code indicates whether the recorded cell was cortical or thalamic. These data include both subcortical and cortical inputs to thalamic cells, and for cortical cells, they represent thalamic input and input from other cortical cells (published data from the author's laboratory).

Three points are evident from Figure 8D. First, the classification of glutamatergic inputs, at least for thalamic and cortical circuits, is quite robust. Second, so far, only two main classes of glutamatergic input have been found. Third, the driver properties for thalamic circuitry are quite similar to those for cortical circuitry, and the same applies to modulator circuits.

One of the key differences between drivers and modulators is the activation of metabotropic glutamate receptors by the latter (144). These metabotropic glutamate receptors are widely distributed throughout the central nervous system, and especially in thalamus and cortex. For this reason alone, considering only participation of ionotropic glutamate receptors (such as AMPA and NMDA receptors) in glutamatergic processing is insufficient. Like other metabotropic receptors (e.g., for acetylcholine, GABA, etc.), metabotropic glutamate receptors are found both postsynaptically on target cells and presynaptically on various synaptic terminals. As noted above, postsynaptic metabotropic receptors differ from ionotropic receptors in requiring higher rates of afferent firing for activation and, when activated, have a much prolonged time course. Two main metabotropic glutamate receptor types exist: activation of group I metabotropic glutamate receptors

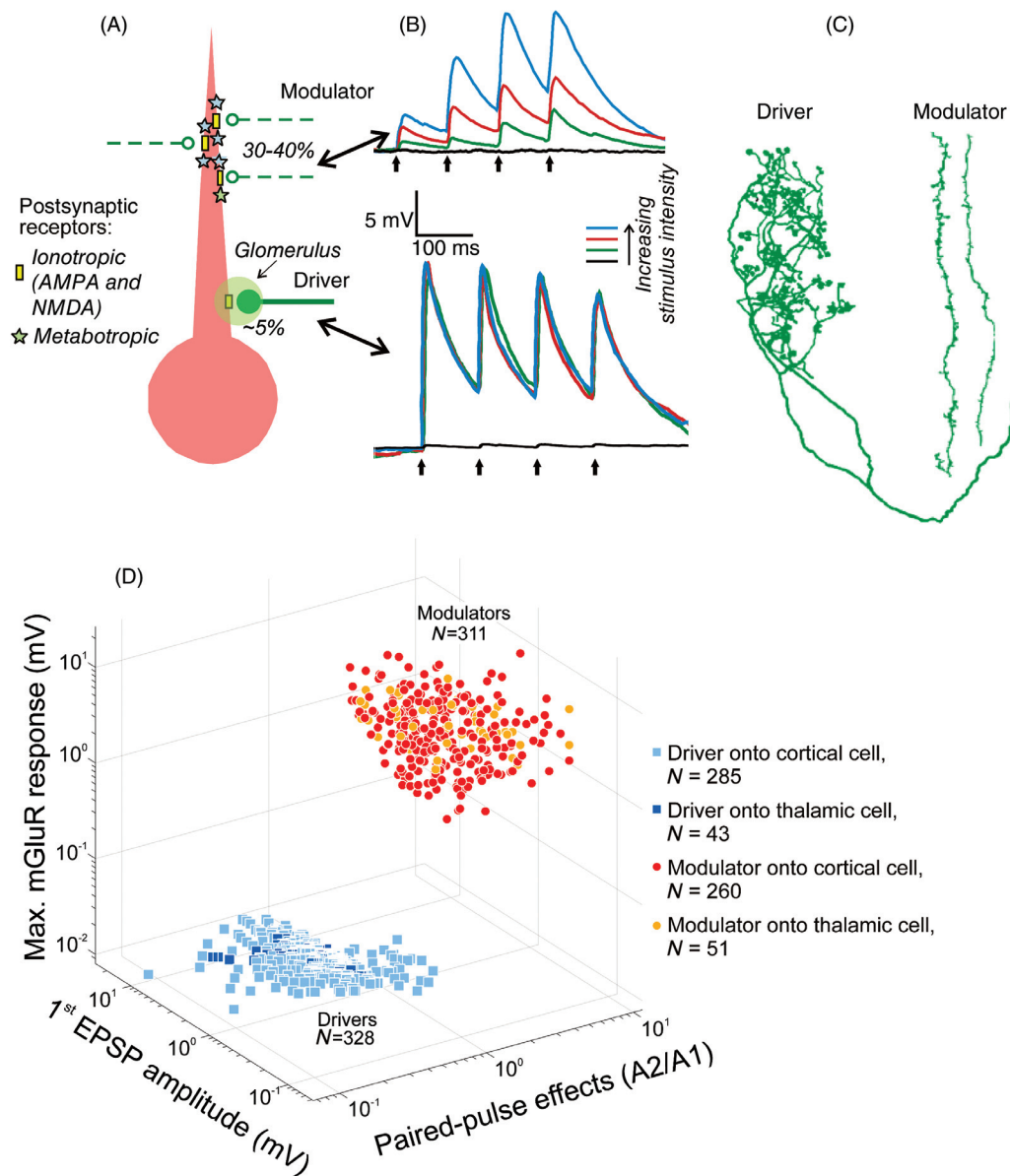

Figure 8 Drivers and modulators. (A) Modulators (dashed green inputs) shown contacting more peripheral dendrites than do drivers (solid green input). Also, drivers activate only ionotropic glutamate receptors, whereas modulators also activate metabotropic glutamate receptors. (B) Effects of repetitive stimulation on EPSP amplitude: for modulators, this produces paired pulse facilitation (increasing EPSP amplitudes during the stimulus train), whereas for drivers, this produces paired pulse depression (decreasing EPSP amplitudes during the stimulus train). Also, increasing stimulus intensity for modulators (shown as different colors) increases EPSPs more than is the case for drivers; this indicates more convergence of modulator inputs compared to driver inputs. (C) Light microscopic tracings of a driver afferent (a retinogeniculate axon from the cat) and a modulator afferent (a corticogeniculate axon from layer 6 of the cat). Redrawn, with permission, from (147). (D) Three-dimensional scatterplot for inputs classified as driver or modulator to cells of thalamus and cortex; data from *in vitro* slice experiments in mice from the author's laboratory. The three parameters are: (1) the amplitude of the first EPSP elicited in a train at a stimulus level just above threshold; (2) a measure of paired-pulse effects (the amplitude of the second EPSP divided by the first) for stimulus trains of 10 to 20 Hz; and (3) a measure of the response to synaptic activation of metabotropic glutamate receptors, taken as the maximum voltage deflection (i.e., depolarization or hyperpolarization) during the 300 ms postsynaptic response period to tetanic stimulation in the presence of AMPA and NMDA blockers. Pathways tested here include various inputs to thalamus from cortex and subcortical sources, various thalamocortical pathways, and various intracortical pathways. Adapted, with permission, from (145).

causes postsynaptic depolarization, usually via closing of K^+ channels; and activation of group II metabotropic glutamate receptors causes hyperpolarization, usually via opening of K^+ channels. Thus group II receptors, provide a means of inhibition in thalamus and cortex apart from GABAergic inputs.

While the classification of these glutamatergic pathways appears to be clear, their different functions are not. Using the lateral geniculate nucleus as an example, evidence from thalamus suggests that the driver input carries the main information for relay. There is also evidence that the modulator (layer 6) input provides a different function that is modulatory and affects how driver input is relayed. Two examples are (i) evidence that the layer 6 input affects the gain of retinogeniculate transmission (see below); and (ii) evidence that this input helps control the burst/tonic transition by controlling the resting membrane potential of relay cells and thus the inactivation state of I_T [see Fig. 6A,B and (5, 106)]. Whether these functional differences hold for cortical circuitry is as yet unclear, but it can be regarded as a reasonable hypothesis for now.

Although the information-bearing role for driver inputs seems fairly straightforward, one might ask why glutamatergic modulators are needed given the array of classical modulatory systems using acetylcholine, noradrenalin, etc. A suggestion for this is that classical modulatory systems are diffusely organized and seem more relevant to overall behavioral state, whereas glutamatergic inputs seem to be highly topographic: topographic modulation is needed for such processes as spatial attention, adaptation, etc.

A final point about drivers and modulators involves numbers. In thalamus, drivers are clearly much less numerous anatomically than modulators in terms of either afferent axons or synapses; for instance, as noted above just among glutamatergic inputs to the lateral geniculate nucleus, layer 6 (modulator) inputs provide an order of magnitude more synapses than do retinal (driver) inputs (42, 168). Whereas precise numbers do not exist for most cortical circuits, a similar numerical disparity has been shown for some cortical circuits as well. For instance geniculocortical inputs onto layer 4 cells, a driver input, accounts for 6% of the synapses there, whereas inputs from layer 6 to these cells, a modulatory input, accounts for 45% (1), relative numbers that are remarkably similar to those just mentioned for retinal versus layer 6 inputs to geniculate relay cells. If indeed driver inputs within cortex are a small minority but represent the all-important vehicle for information transfer, it becomes particularly important to identify this subset as a prerequisite for understanding the functional organization of cortical circuits.

The Layer 6 Corticothalamic Pathway

The anatomically largest single input to thalamus derives from layer 6 of cortex. As noted above, this input is a glutamatergic modulator, and its effect on thalamic relay cells relies to a large extent on its relationship to relay cell and local inhibitory targets (Figs. 3 and 5). It should also be clear from Figure 3B,C

that attempts to determine the function of this pathway by its general suppression via cortical lesions or cooling or by more modern methods involving optogenetics will end up removing both direct excitation and indirect inhibition of relay cells; only methods that control individual layer 6 cells can be expected to distinguish between the alternatives of Figure 3B,C and produce clear effects on relay cells. This may be why many early attempts to understand the layer 6 corticothalamic pathway by large-scale cortical ablation or cooling has led to a confusing and often contradictory mixture of claims of subtle effects [e.g., (7, 49, 77, 101, 102, 131, 138, 151)]. Even modern approaches using optogenetics to control the layer 6 pathway has proven contradictory, with one study claiming that activating the pathway reduces geniculocortical transmission (115) and another claiming that that this reduction from layer 6 activation occurs when the layer 6 cells are initially firing at low rates, but when firing at high rates, activating the pathway further serves to increase thalamocortical transmission (31).

It may well be that there is no single role that can be ascribed to this pathway, because it is heterogeneous and thus likely to have multiple functions. Evidence for heterogeneity among the layer 6 projecting cells has existed for some time (152, 165), and so any attempt to find a single function for this reciprocal feedback may be fruitless. More recent evidence indicates that at least some of the heterogeneity can be linked to parallel processing in thalamocortical systems. For instance, as noted above, the retino-geniculo-cortical pathway involves three separate streams (W, X, and Y in cat or K, P, and M in monkey). Each of the three streams has its own distinct geniculate relay cell type [(reviewed in (140, 188)], and it appears that different classes of layer 6 cell innervate each of these relay cell types (15, 17).

Finally, an important feature of the layer 6 corticothalamic axons is that they branch to also innervate the layer 4 cells that are main target of thalamocortical axons (Fig. 9). This means that these axons can affect thalamocortical transmission both at its source in thalamus as well as its main target in cortex, and indeed evidence exists that this is the case. Much of this has to do with the modulator properties of this pathway and its ability to activate metabotropic glutamate receptors. At least four independent sites of action of the pathway have so far been demonstrated, and these are outlined in Figure 9 [1] The IPSP activated indirectly in thalamic relay cells via the local GABAergic cells tends to be larger than and can swamp the direct EPSP (85); [2] cortical activation of *presynaptic* metabotropic glutamate receptors on retinal terminals reduces transmitter release and thus the gain of retinogeniculate transmission (51, 86); [3] layer 6 input onto thalamocortical target cells in layer 4 often produces sustained hyperpolarization through activation of postsynaptic group II metabotropic glutamate receptors (90); and [4] layer 6 input to layer 4 cells activates metabotropic glutamate receptors presynaptically on thalamocortical terminals to reduce transmitter release and down regulate thalamocortical EPSPs (92). Note that each of these actions would result in a reduction of

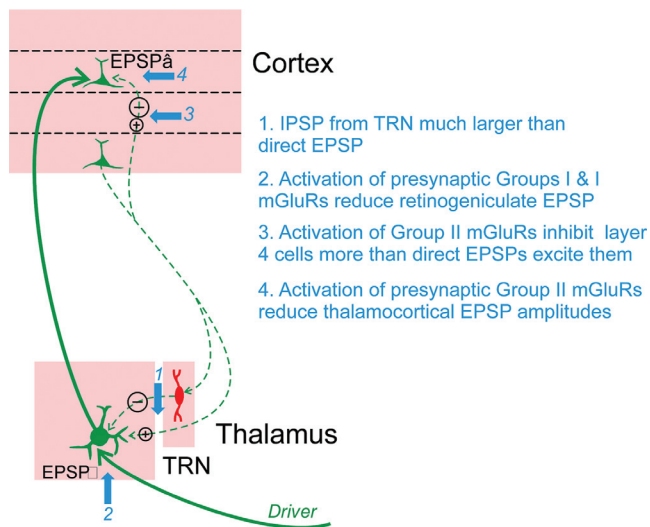

Figure 9 Schematic summary of synaptic effects of layer 6 corticothalamic cells on thalamocortical transmission. Note that these cells have bifurcating axons that innervate both layer 4 cells postsynaptic to thalamic input as well as thalamic circuitry. Four distinct effects have been documented, each of which serves to reduce the gain of thalamocortical transmission. See text for details.

the gain of thalamocortical transmission, and in this regard, it is more consistent with the recent demonstration that reaches a similar conclusion from optogenetic control of the pathway (115).

Transthalamic Pathways

A key to understanding a major function of any thalamic nucleus is to identify its driver input, because one then knows the source of information to be relayed to cortex. Thus, we largely define the lateral geniculate nucleus as relaying retinal information. Likewise, other nuclei that we now call first order can be defined in this way: the medial geniculate nucleus relays auditory input from the inferior colliculus, the ventral posterior nucleus, somatosensory input from the medial lemniscus, parts of the ventral anterior/ventral lateral complex, motor input from the deep cerebellar nuclei, etc. (148). These examples of primary sensory relays have long been understood to relay subcortical information from retina, spinal cord, or brainstem to cortex.

First and higher order relays

A significant advance in our understanding of thalamocortical relationships comes from work in many laboratories, work that provides a fairly clear picture of a new source of driver input to much of thalamus: that from layer 5 of cortex [(reviewed in (56, 148)]. Thus, whereas all thalamic nuclei receive a cortical input from layer 6 that is organized predominantly in a reciprocal feedback manner, some nuclei, in addition, receive another cortical input, from layer 5, that is not reciprocal (e.g., feedforward only). This layer 5 input

has driver properties, basically the same as the retinogeniculate input (148). As a result, we can now define two types of thalamic relay (Fig. 10): *first order* relays receive subcortical driver input (e.g., retinal input to the lateral geniculate nucleus) and represent the first relay to cortex of a particular type of information (e.g., visual), whereas *higher order* relays receive driver information from layer 5 of cortex, and thus represent part of a cortico-thalamo-cortical, or transthalamic, pathway that relays information already in cortex but from one cortical area to another. Again, this means that higher order relays receive two distinct cortical inputs: one from layer 6 that is organized as a reciprocal feedback, and the other from layer 5 that is not reciprocal.

The main sensory systems have clear examples of first and higher order thalamic relays [(reviewed in (148)]: for vision, the lateral geniculate nucleus is first order, and the pulvinar, higher order; for somesthesia, the ventral posterior nucleus is first order, and the posterior medial nucleus, higher order; for hearing, the ventral division of the medial geniculate nucleus is first order, and the dorsal division, higher order. The ventral anterior and ventral lateral nuclei, which form a thalamic complex involved in relaying motor information, appear to be organized in a mosaic fashion, with one zone being first order, receiving cerebellar driving afferents, and the other zone, higher order. The medial dorsal nucleus seems largely if not wholly organized as a higher order relay for transthalamic traffic between frontal cortical areas. By far, the two largest thalamic nuclei are the pulvinar and medial dorsal nucleus, both higher order, and while not all of the thalamus has been parsed in this fashion, it appears that the clear majority, by volume, is higher order. We can thus suggest a fairly straightforward function for many thalamic nuclei that heretofore have been rather mysterious functionally: these nuclei are higher order relays and serve as a conduit for information transfer between cortical areas.

Although the circuitry of first and higher order thalamic nuclei are quite similar except for the origin of their driver inputs (e.g., Fig. 8), a number of quantitative differences between them have been documented and are simply listed here.

- The relative percentage of driver versus other synapses is significantly lower in higher order relays at roughly 2% versus 5% (168, 169, 180), suggesting that there is relatively more modulation of higher order relay cells.
- Serotonergic and cholinergic inputs from the brainstem depolarize all first order relay cells but a significant minority (1/4 to 1/3) of those in higher order nuclei are hyperpolarized by these inputs due to different receptors to these neurotransmitters (171, 172).
- Higher order thalamic nuclei receive substantial GABAergic inputs, from the zona incerta, substantia nigra, basal ganglia, and pretectal region, that do not extensively innervate first order nuclei (11, 58, 83, 87, 136)

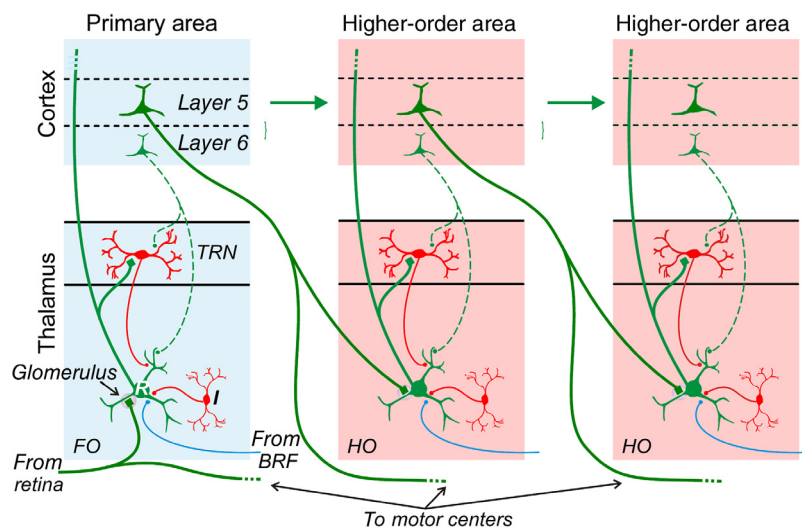

Figure 10 Schematic diagrams showing organizational features of first and higher order thalamic nuclei. A first-order nucleus (*left*) represents the first relay of a particular type of subcortical information to a first-order or primary cortical area. A higher-order nucleus (*center and right*) relays information from layer 5 of one cortical area up the hierarchy to another cortical area. This relay can be from a primary area to a higher one (*center*) or between two higher-order cortical areas (*right*). The important difference between first- and higher-order nuclei is the driver input, which is subcortical for a first-order relay and from layer 5 of cortex for a higher-order relay. Note that all thalamic nuclei receive an input from layer 6 of cortex, which is mostly organized in a reciprocal feedback manner, but higher-order nuclei in addition receive a layer 5 input from cortex, which is feedforward. Note that the driver inputs, both subcortical and from layer 5, are typically from branching axons, with some extrathalamic targets being subcortical motor centers, and the significance this is elaborated in the text. *Abbreviations:* BRF, brainstem reticular formation; FO, first order; HO, higher order; TRN, thalamic reticular nucleus. Redrawn, with permission, from (143).

- Bursting based on activation of T-type Ca^{2+} channels is more frequent among higher order relay cells (128); this may be related to the above points that higher order relays receive more hyperpolarizing inputs via GABAergic, serotonergic, and cholinergic innervation, which serve to deactivate T-type Ca^{2+} channels in more relay cells, thereby promoting more burst firing.
- All relay cells in first order nuclei appear to be first order, meaning that they all receive subcortical drivers, but nuclei identified as higher order appear to include some first order circuits. For instance, the superior colliculus seems to provide driving input to a minority subset of cells of the pulvinar and medial dorsal nucleus as does the spinal trigeminal nucleus for some cells of the posterior medial nucleus (9, 53, 79, 122, 156). There is no evidence of direct connections between relay cells, and so each can be regarded as an independent link in the relay to cortex. Therefore, relay cells can clearly be first or higher order, and what we refer to as first order nuclei (e.g., the lateral geniculate nucleus) contains only first order relay cells, whereas what we refer to as higher order nuclei (e.g., the pulvinar) contain mostly higher order relay cells but some first order ones as well.
- First order relays innervate cortex in a feedforward manner, since they are the first relay of a particular kind of information to cortex and predominantly innervate primary cortical areas. However, some relay cells of the pulvinar, posterior medial nucleus, and dorsal division of the medial geniculate nucleus innervate primary visual, somatosensory, and auditory cortices, as well as higher areas, raising the possibility that some higher order inputs to cortex are organized in a feedback manner.
- First order relay cells generally transfer information from one or a few driver inputs without further significant elaboration of the information carried [e.g., but see (10)], whereas evidence exists for such elaboration for some higher order relay cells, where single neurons in the posterior medial nucleus or pulvinar are innervated both by layer 5 and subcortical driver inputs (54). This is a critical issue and needs indisputable confirmation, because current ideas of thalamic processing do not include elaboration of information based on significant convergence of driver inputs.

Neuronal substrate for corticocortical communication

Since relay cells project to cortex, and higher order ones receive driver input from layer 5 of cortex, it follows that those relay cells in higher order thalamic nuclei pass information from one cortical area to another. The clearest example

of such a transthalamic pathway is a projection from layer 5 of primary somatosensory cortex to the higher order posterior medial nucleus to the second somatosensory area (129, 164, 177). Furthermore, suppression of primary somatosensory cortex, which eliminates layer 6 input to cells of the ventral posterior medial nucleus, has little effect on these cells, but such suppression also eliminates layer 5 input to cells of the posterior medial nucleus, and this procedure renders these latter thalamic cells insensitive to sensory stimulation, further suggesting that they receive their driver input from cortex (37). Less comprehensive but nonetheless compelling evidence also exists for such circuits in the visual and auditory systems [(reviewed in (148)]. For instance, the pulvinar in both cat and monkey has neurons that seem to possess receptive field properties inherited from cortical input, suggesting that they receive cortical driver input and serve as a link in transthalamic circuitry (8, 23, 107, 190). Moreover, other evidence indicates that the pulvinar in the monkey participates in transthalamic pathways to regulate information transfer between cortical areas (135). In the auditory system, anatomical evidence exists that the dorsal division of the medial geniculate nucleus receives driver input from layer 5 of primary auditory cortex (96, 113, 114). Finally, a recent study using optogenetics and Ca^{2+} imaging in mice has shown that activation of cortical layer 5 cells produces waves of activity in other cortical areas, and these activation waves depend on transthalamic pathways (160).

Figure 10 also shows another interesting feature of these transthalamic pathways. Often, where a direct pathway connects two cortical areas, a transthalamic pathway does so as well in parallel. This raises three related questions:

- How common is this parallel arrangement, or, conversely, how common are direct or transthalamic pathways the sole link between cortical areas?
- What is different between the information carried by the direct versus the transthalamic pathway?
- Why is one of these pathways filtered through the thalamus?

The observation that direct and transthalamic pathways are often if not always organized in parallel raises another question regarding the extent to which these circuits are independent, especially since a recent study suggests a degree of independence between these pathways. That is, cortical cells that project to other cortical areas and those that project subcortically (either from layer 5 or from layer 6) are nearly completely separate populations (123). This is consistent with the notion that the direct and transthalamic pathways carry different messages.

Do feedback transthalamic pathways also exist?

The above discussion of transthalamic pathways has been focused on feedforward circuits, such as from primary

somatosensory cortex through the posterior medial nucleus to the secondary cortical area (164). However, there is reason to suspect that transthalamic feedback pathways also exist. This is largely based on some evidence, limited to be sure, that higher order thalamic inputs to primary cortical areas provide modulatory input, whereas their inputs to higher order areas appear to be driver (177). Further evidence of this arrangement of higher order relays modulating primary areas comes from studies of effects of modulating pulvinar input on responses in primary visual cortex in the mouse (134) and Galago (a prosimian primate) (124).

A key question not yet resolved is the source of driver input to these higher order thalamic cells that project to primary cortical areas: if this source turns out to be layer 5 cells of higher cortical areas, then this would represent a transthalamic feedback modulatory pathway, but other sources exist (e.g., the superior colliculus for pulvinar or the fifth spinal nucleus for the posterior medial nucleus). Also, to the extent that direct feedback pathways exist in cortex, such putative transthalamic feedback pathways could be organized in parallel with the direct ones in much the same way that feedforward corticocortical pathways are organized. Obviously, this idea of feedback transthalamic modulatory pathways is purely hypothetical at present, but it seems a plausible hypothesis for testing.

Examples of Value of Driver/Modulator Identification

At this point, a minor detour is made to consider the value of the driver/modulator distinction in the context of transthalamic corticocortical pathways. Two examples, among others, are offered, one involving processing related to the auditory thalamus and the other involving the nature of the relationship between the basal ganglia and thalamus.

Pathways from the inferior colliculus to the medial geniculate nucleus

The standard view of the projections from the inferior colliculus to the medial geniculate nucleus is illustrated in Figure 11A. In this scheme, there is a parallel organization for auditory information relayed through thalamus: a lemniscal stream starting with the core region of the inferior colliculus and relayed through the ventral part of the medial geniculate nucleus; and a paralemniscal stream starting with the shell region of the inferior colliculus and relayed through the dorsal part of the medial geniculate nucleus (64, 181). However, this conclusion implicitly assumes that both inputs to the medial geniculate nucleus are driving inputs. An experiment designed to test this idea documented a different picture (Fig. 11B): the lemniscal input to the ventral division of the medial geniculate nucleus is indeed a driver, but that of the paralemniscal is a modulator (91). Therefore, rather than having a parallel organization of information pathways from the

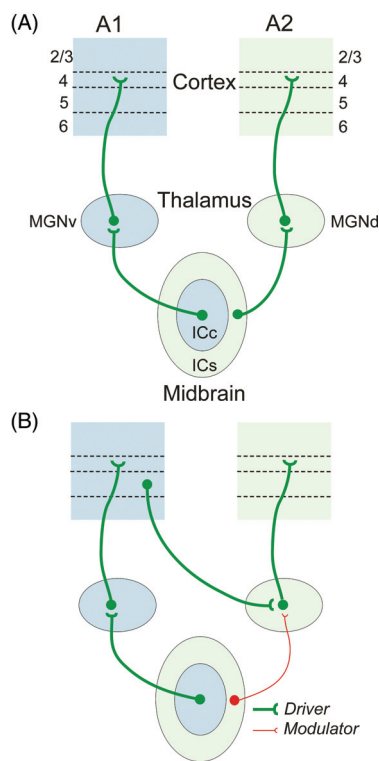

Figure 11 Two views of tectothalamic inputs in auditory pathways. Shown are projections from the core region of the inferior colliculus (ICc) to the ventral part of the medial geniculate nucleus (MGNv) and from the shell region of the inferior colliculus (ICs) to the dorsal part of the medial geniculate nucleus (MGNd). (A) View of parallel processing. Two information streams are shown, one from ICc through MGNv to primary auditory cortex (A1) and the other from ICs through MGNd to secondary auditory cortex (A2). (B) View incorporating identification of drivers and modulators. The stream from ICc through MGNv involves driver paths and thus represents an information stream. However, the input from ICs to MGNd is a modulator, whereas the driver input to MGNd arises from layer 5 of cortex. Thus, in this view, the projection from ICs to MGNd modulates this transthalamic circuit.

inferior colliculus through the medial geniculate nucleus, the picture that emerges is as follows: the input from the core region of the inferior colliculus that is relayed through the ventral part of the medial geniculate nucleus is a first order information route, whereas that from the shell region of the inferior colliculus serves to modulate the transthalamic pathway relayed through the dorsal part of the medial geniculate nucleus. A comparison of the schemas in (Fig. 11A and B) demonstrates how identifying driver versus modulator pathways dramatically changes the understanding of how circuits operate.

Basal ganglia innervation of thalamus

The textbook view describes a loop of information flow that involves a projection from cortex to the basal ganglia, from the basal ganglia to thalamus, and from thalamus to cortex, back to basal ganglia, etc. (Fig. 12A). However, according to the view proposed here, this represents an information loop only if the connections described include drivers. They do

not. The thalamocortical input is likely a driver input, and that from cortex to basal ganglia might be (although it has not yet been tested for this property), but that from the basal ganglia to thalamus is GABAergic. We have argued elsewhere that GABAergic inputs are relatively poor conveyers of information and thus should not be thought of as likely drivers (154).

The main thalamic target of the basal ganglia is the ventral anterior/ventral lateral complex. The ventral anterior and ventral lateral nuclei are recognized as separate nuclei in monkeys, but in cats and rodents, they are hard to distinguish, and in general seem to be one rather complicated functional unit. Thus, we refer to this region of motor thalamus as the ventral anterior/ventral lateral complex. Of interest in both rats and monkeys is the observation that this complex is organized as a sort of mosaic, with an input from the deep cerebellar nuclei projecting to one representation of the mosaic and the basal ganglia projecting to the other (84, 136). Perhaps this thalamic complex should be renamed, with one term representing the cerebellar input zone, and the other, that of the basal ganglia.

The cerebellar input has the properties of a driver, making this part of the thalamic mosaic a first order relay [(reviewed in (148)]. Furthermore, this thalamic complex receives layer 5 innervation from motor cortex (104), making this part of the thalamic mosaic a higher order relay. It is likely that the first and higher order regions of the complex are non-overlapping, and this means that the basal ganglia innervates the higher order part of this complex. Figure 12B shows this schema, and this suggests that, rather than providing an information route via thalamus to cortex, the basal ganglia serves to gate transthalamic circuits.

Further examples of this function for basal ganglia input to thalamus are shown in Figure 12C,D. When active, the basal ganglia input can block transthalamic circuits and allow them when inactive. In this regard, the basal ganglia serves to determine which transthalamic pathways operate (Fig. 12C). Related to this, imagine that a given cortical area connects with many others via direct and transthalamic circuits; in this example, input to thalamus from the basal ganglia can determine which pairs of cortical areas are connected by activity in both direct and transthalamic circuits (Fig. 12D), and, as noted below, summation properties of the two pathways at their cortical target area could prove an important parameter in cortical functioning.

As above for Figure 11, a comparison of Figure 12A and B shows how an identification of driver pathways provides a very different view of circuit functioning.

Axonal Branching and Driver Inputs to Thalamus

Axonal branching is a common feature of pathways in the central nervous system. An important property of such branching is that it serves to pass the *identical* message to all targets of

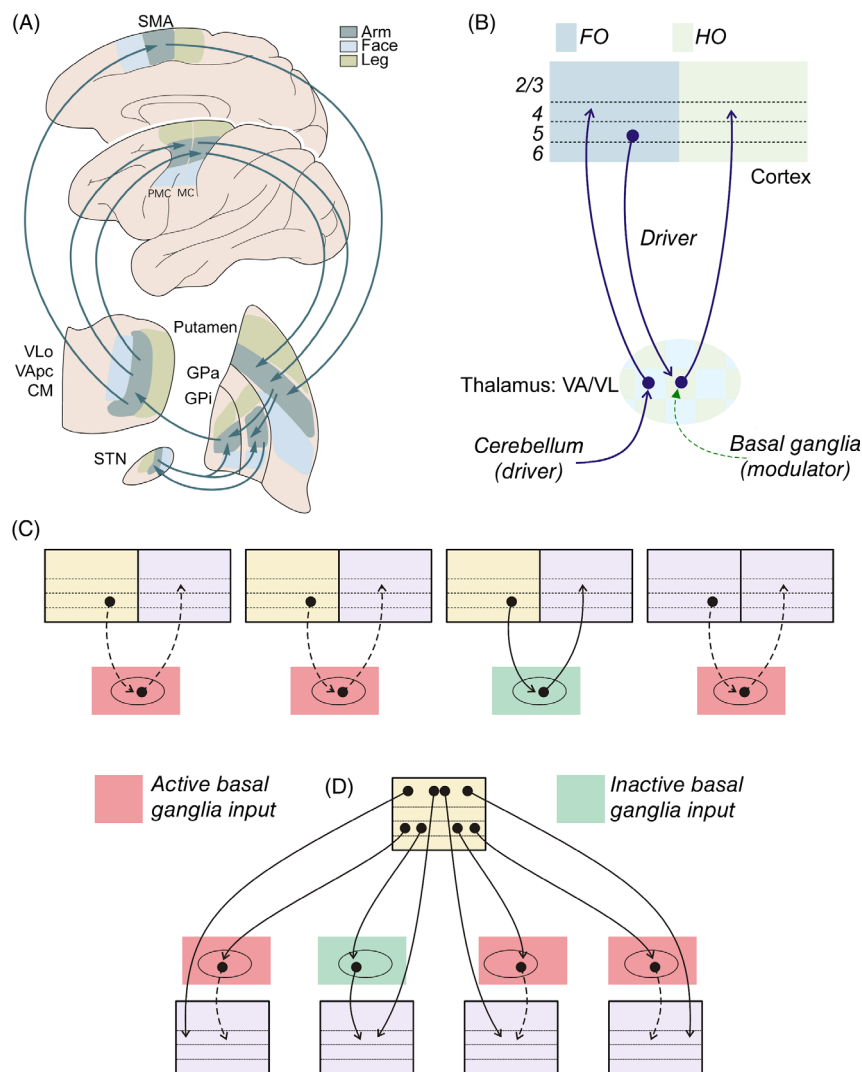

Figure 12 Two views of the relationship between the basal ganglia and cortex. (A) Text-book view. This depicts a simple information loop, the information flowing from thalamus to cortex to basal ganglia to thalamus, etc. Adapted, with permission, from (78). (B) Different view incorporating the idea that information is carried by glutamatergic driver pathways. Since the basal ganglia outputs are strictly GABAergic, this input to thalamus serves not as an information route but rather modulates a transthalamic pathway through the higher-order portion of the motor thalamus. When active, the basal ganglia input would shut down the higher-order thalamic relays, providing a gating mechanism. (C) One example of this is that the basal ganglia input to thalamus can determine which combinations of transthalamic pathways are active at any given time; dashed thalamocortical pathways indicate that these are nonactive due to basal ganglia inhibition. (D) A related example is that the basal ganglia can determine which cortical areas are actively connected by both direct and transthalamic pathways, and not just the former. See text for details.

the axon. That is, the same pattern of action potentials passes down all branches to their terminals. This does not mean that all targets respond identically, because different synaptic properties likely exist at different terminals. Nonetheless, axonal branching is the most effective way to share a common message from one neuron to multiple targets.

It follows that identifying such branching in neuronal circuits is of utmost importance to understanding how different brain areas communicate with one another. However, there are serious technical limitations that need to be understood.

Generally, there are three traditional ways to identify such branching: (i) the physiological approach of antidromically activating a recorded neuron from multiple sites; (ii) the anatomical approach of multiply labeling a neuron from retrograde tracers placed in several sites; and (iii) the anatomical approach of orthogradely tracing labeled axons (e.g., via Golgi staining or orthograde label placed into single cells). All are deeply flawed. Antidromic activation is technically difficult and rarely applied to test for branched axons, and when applied, suffers from a high degree of false negatives.

That is, failure to find multiple sites for antidromic activation could be simply because of failure to stimulate the correct target zone(s). Likewise, multiple retrograde labeling also suffers from false negatives, mainly for a similar reason: failure to deposit the label in the correct target zone(s). By far, the most reliable technique to identify branched axons is orthograde tracing, but there are serious flaws here as well. Golgi staining is notoriously unreliable, and one cannot count on complete labeling of processes or cell types of interest. That leaves orthograde labeling of single cells, and although, when applied, is the best method, its degree of difficulty is so great that it is rarely used.

For these reasons, orthograde labeling has not been systematically applied to detect branching within thalamic and cortical circuits. This applies in particular to thalamic afferents. There is nonetheless enough scattered evidence to make the case that driver afferents to thalamus frequently, and perhaps always, branch and thereby also target other subcortical sites.

Branching driver afferents to first order thalamic relays

The best-studied driver input to thalamus is the retinal input, and considerable evidence exists that most or all retinogeniculate axons studied to date branch to also innervate the superior colliculus and pretectal regions of the midbrain (24, 95, 163, 170). Figure 13A shows an example from the cat. Scattered but very limited data also indicate branching of driver inputs to the ventral posterior nucleus (18, 173) and medial geniculate nucleus (88).

Limited evidence also exists for branching of driver inputs to other first order relays outside the main sensory pathways. Afferents to the ventral anterior/ventral lateral motor thalamic complex from the cerebellum have the anatomical features of large terminals that often participate in triadic relationships (82, 83), and this marks these afferents as drivers [(reviewed in (148)]; these branch to also innervate the red nucleus and tectal reticular nucleus (19, 103, 150) (Fig. 13B). Inputs

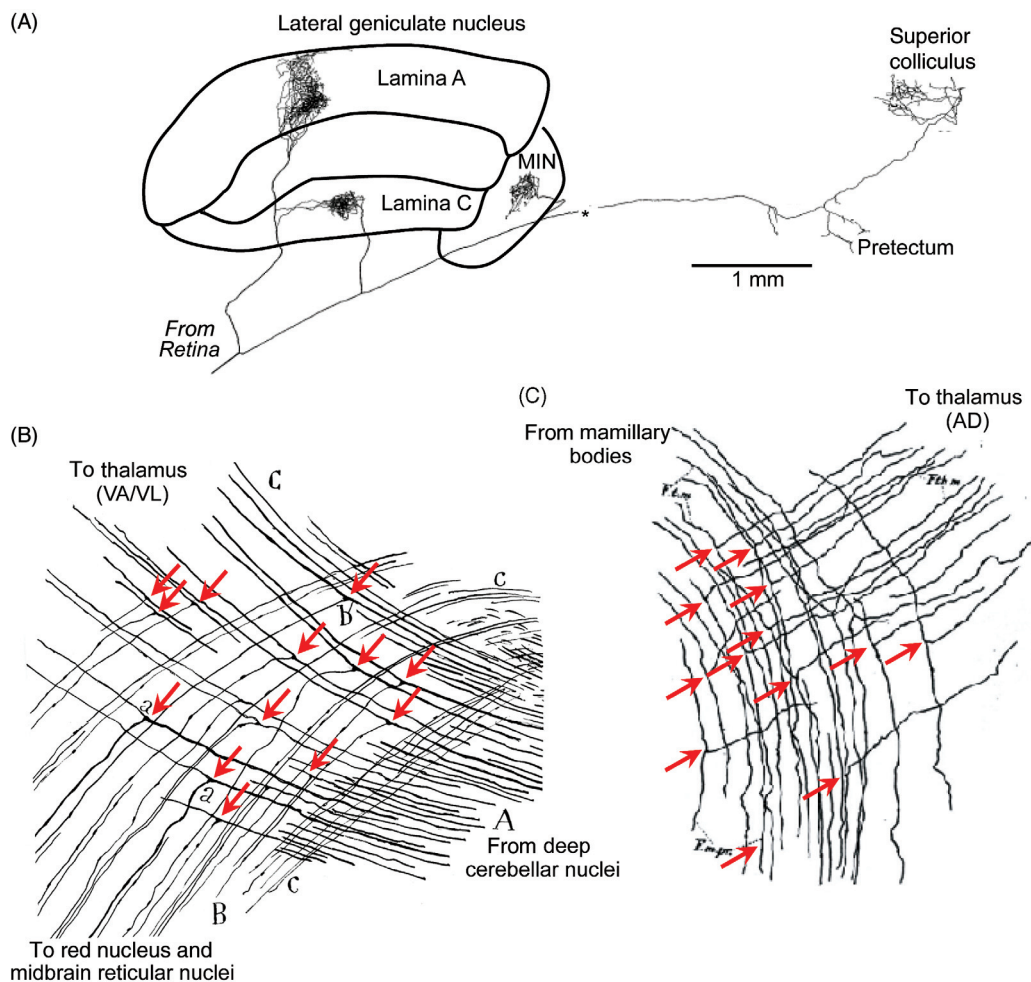

Figure 13 Branching driver inputs to representative first order thalamic relays. (A) Example from retinogeniculate axon of cat; redrawn, with permission, from (163). (B) Example of cerebellar inputs to the ventral anterior and ventral lateral nuclei (VA/VL); redrawn, with permission, from (19), and thanks to Javier deFelipe for providing this image. (C) Example of mammillary inputs to the anterior dorsal nucleus (AD); redrawn, with permission, from (81). Red arrows in B and C indicate branch points.

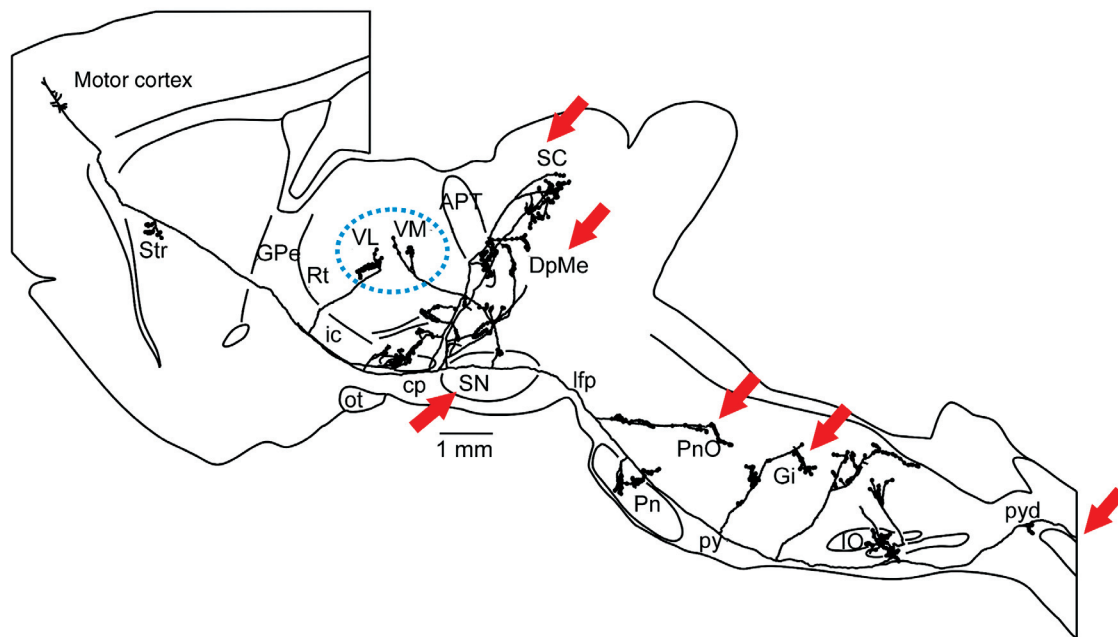

Figure 14 Example from layer 5 pyramidal tract cell of rat motor cortex; redrawn, with permission, from (80); tracing of reconstruction generously supplied by H. Kita. Branches innervating thalamus are indicated by the dashed blue circle, and brainstem motor regions are indicated by red arrows. *Abbreviations:* cp, cerebral peduncle; DpMe, deep mesencephalic nuclei; Gi, gigantocellular reticular nucleus; GPe, Globus pallidus external segment; ic, internal capsule; IO, inferior olive; Pn, pontine nucleus; PnO, pontine reticular nucleus, oral part; py, medullary pyramid; pyd, pyramidal decussation; Rt, thalamic reticular nucleus; SC, superior colliculus; SN, substantia nigra; Str, striatum; VL, ventrolateral thalamic nucleus; VM, ventromedial thalamic nucleus.

from the mammillary bodies to the anterodorsal nucleus are drivers (121), and these branch to innervate the dorsal and deep tegmental nuclei (55, 81) (Fig. 13C). Furthermore, vestibulothalamic axons branch to innervate the interstitial nucleus of Cajal, central grey substance, and spinal cord (67, 99). The main point here is that, each time it has been appropriately tested, subcortical driver inputs to thalamus are seen to branch to innervate extrathalamic brainstem targets as well.

Branching driver afferents to higher-order thalamic relays

The layer 5 projections to thalamic relay cells so far studied all appear to be driver inputs, and so far all of these that have been appropriately documented arrive via branched axons (148). As noted earlier, more systematic study using orthograde tracing techniques are needed to determine how common this pattern is, but a number of examples serve to support its generality. These layer 5 corticothalamic examples include: projections in the rat from motor, somatosensory, and visual cortices that branch to innervate various midbrain and pontine areas (12, 13, 36, 80, 174); projections in the cat from visual cortex to the pulvinar that branch to innervate midbrain (21); and projections in monkeys from primary visual cortex and the middle temporal area that innervate pulvinar and branch to innervate midbrain (132). A further and

particularly impressive example is illustrated in Figure 14, which shows a motor cortex pyramidal tract neuron that branches extensively to innervate the ventrolateral and ventromedial thalamic nuclei as well as numerous sites in the brainstem and targets (undefined) in the spinal cord (80). Of particular interest here, many of these layer 5 extrathalamic targets are motor in nature, including bulbospinal control regions (e.g., tectospinal, rubrospinal, and reticulospinal [reviewed in (57, 148)]) and, of course, the spinal cord itself. Another important point that needs emphasizing and is reiterated below is that every cortical area so far studied in this regard, including primary sensory areas, sends branching projections from layer 5 to subcortical targets, some of which are motor centers.

This pattern of branching provides a possibly key difference between the direct and transthalamic pathways between cortical areas (see also later). That is, the direct pathways rarely if ever involve axons with subcortical branches, meaning that the information carried by direct corticocortical axons is information that stays strictly within cortex. In contrast, the transthalamic pathways involve information that is shared with multiple subcortical parts of the neuraxis. Furthermore, as noted above, whereas corticocortical axons seem not to have subcortical targets, corticofugal axons from one area of cortex rarely branch to innervate other cortical areas, suggesting a degree of independence in the direct and transthalamic cortical circuits (123).

Driver inputs to thalamus and efference copies

Efference copies. When an animal makes a movement, it changes its relationship with its environment, and this creates a potential problem for the organism: are the changes due to the animal's own movement or due to real changes in the environment? Consider what happens when we move our eyes. A leftward gaze necessarily induces an image on the retina of the world moving in the opposite direction, but we do not normally experience this: somehow, we know the movement on the retina is due to our own behavior. The result is that we experience a stabilized world and can disambiguate self-generated actions from environmental events. Likewise, when we manipulate an object with our hands and fingers, we can discriminate features of that object by separating tactile experiences we induce by our actions from those that movement of the object might evoke. Efference copies are needed for these examples of disambiguation of self-generated actions from environmental events. It is important to note that this process requires a prediction, or a "forward model," of what will occur as a result of the impending action, and that any sensory feedback that can indicate the position of the eyes or finger joints would occur *after* the movement and be too late for this purpose (157).

This problem has long been appreciated, and as early as the nineteenth century, Helmholtz (62) recognized that the brain evolved a mechanism to deal with it. This mechanism involves a special type of neuronal message that has been termed *efference copy*. (The message is also known as "corollary discharge," and while some argue for subtle preference of one or the other term, they are usually used interchangeably; we will stick with the term "efference copy" here, because of the importance of this involving a mechanism to produce precise copies of messages sent via brain circuits.) This is a copy of the signal sent to motor centers to produce a behavior (e.g., an eye movement), and the idea is that this copy is sent back into the appropriate sensory pathways so that the self-generated behavior can be accounted for in the ongoing sensory processing. Efference copies were first demonstrated in 1950 independently in flies (179) and fishes (159). This has since been demonstrated in multiple animals and systems, and this and other details of efference copy are beyond the scope of this article but can be found elsewhere (157, 185, 187). The fact alone that efference copies were found in flies and fishes indicates that it is part of our early evolutionary heritage (see also below) and must occur widely in the animal kingdom. Indeed, coordinated behavior of any reasonably complex animal without efference copies is implausible.

Axonal branching as a substrate for efference copies. The most efficient and foolproof way of sending copies of an identical message in neural circuits is to make use of axonal branching. This is because, as noted above, the identical pattern of action potentials, which is after all the neuronal message, is sent down every branch of that axon. Different target cells may respond differently to the same message due to different synaptic and cellular properties, but this is still the

best way to deliver the identical message to multiple targets. An alternative, to have different neurons send the same message, each to a different target, invites error, since each of these neurons might respond differently to the input intended to create the message. Given that efference copies are best served by identical copies of the motor messages being sent back into the appropriate processing streams, axonal branching would seem like an ideal means of achieving that.

Figure 15 shows how this might work for spinal circuits. Cajal (19) pointed out that primary afferents to the spinal cord branch, with one branch heading to motoneuron pools in the gray matter and another ascending to the brain (Fig. 15A). Figure 15B shows a schematic view of this. Clearly, we can regard the branch innervating the ventral horn of the spinal gray as a motor message. It thus follows that the branch ascending to the brain is an exact copy of that motor message. This is the definition of an efference copy. It is important to recognize that, in this view, the ascending branch carries a message that has two meanings: a sensory message (e.g., about a joint movement or skin indentation) as well as an efference copy about an impending motor action related to the sensory message. This concept of a message having two meanings is often difficult to grasp, but one way to think about it is that the ascending branch could further branch to innervate different cell groups, one treating the message in sensory terms, and the other, as an efference copy.

It follows that the branching afferents that serve as driver input to thalamus carry copies of messages to extrathalamic targets, and to the extent that any of these targets are motor centers, these thalamic afferents may be considered efference copies. This is illustrated in Figure 10. Good examples are retinogeniculate axons that branch to also innervate mid-brain structures, the pretectal region and superior colliculus (Fig. 13A), that are involved in the control of eye movements, pupillary size, etc. In this sense, retinogeniculate axons are like the primary spinal afferents illustrated in Figure 15: their messages serve both to provide sensory information more centrally, information that can also be interpreted by the appropriate targets as an efference copy.

Early anatomists provided other examples of this relationship, two of which are described above and shown in Figure 13B and C. A particularly dramatic example of this is shown in Figure 14, which is a pyramidal tract axon that branches to innervate thalamus plus many brainstem motor sites (red arrows) in addition to entering the spinal cord to have more direct effects on motoneurons.

Logic dictates that cortex has motor outputs that effectively alter behavior. That is, whereas most attention regarding cortical circuitry has focused on local connections and those between cortical areas, none of these has any direct bearing on overt behavior. Indeed, without effective projections from cortex to subcortical motor centers to affect behavior, cortex would be pretty useless (except perhaps as a covering to protect the thalamus). As noted above, there are two distinct types of corticofugal projection: one from layer 6, and

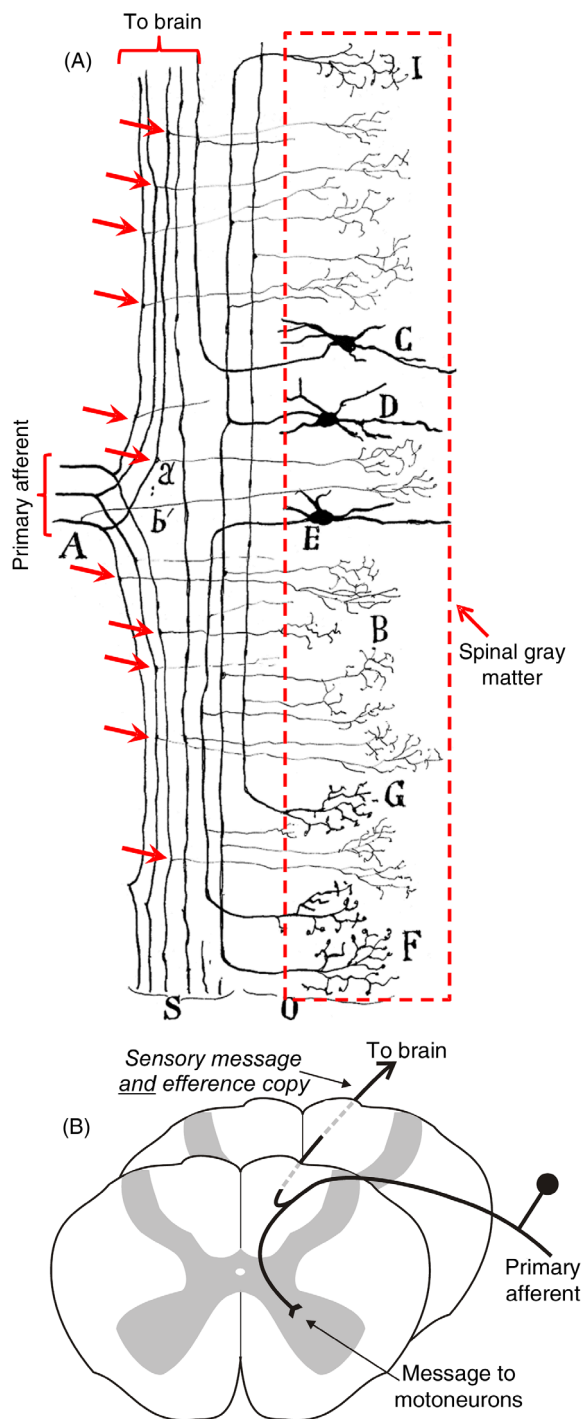

Figure 15 Branching axons. (A) Cajal illustration (19) of primary axons entering the spinal cord and branching to innervate the spinal gray matter and brain areas. The red arrows indicate branch points. Thanks to Javier deFelipe for providing this image. (B) Schematic interpretation of A.

the other from layer 5. Those from layer 6 essentially only innervate thalamus and thus are limited to affecting thalamocortical processing rather than more directly affecting behavior. Clearly, the relevant cortical outputs for motor messages emanate from layer 5. It thus follows that at least some layer

5 outputs carry significant motor messages to targets such as the superior colliculus and various other sites of supraspinal control as well as the spinal cord itself. To the extent that many if not all of these also branch to innervate thalamus, by the logic developed here, these branches are efference copies [for further elaboration of this idea, see (57, 148)].

Furthermore, just as the retinogeniculate axon of Figure 13A and the ascending axon branch in Figure 15B contain related information about a sensory event and possible impending motor action, so do these layer 5 driver inputs to higher order thalamus carry a double message to be relayed up the cortical hierarchy: information processed by the lower level of the hierarchy as well as an efference copy. In other words, this hypothesis proposes that, as a cortical hierarchy is ascended, each level is kept informed of possible motor commands initiated by lower levels based on the same message that summarizes the information processing carried out at that lower level.

Most considerations of efference copies are at a very abstract level and rarely achieve any anatomical detail. The several efforts that have been directed at specific anatomical substrates for efference copy mostly relate to studies of eye movements. For example, a recent study has demonstrated that an efference copy signaling a saccadic eye movement is sent from the superior colliculus to the medial dorsal nucleus of the thalamus for relay to the frontal eye field in cortex (187). Here, the projection from the superior colliculus to thalamus is a copy of a message sent from the colliculus to brainstem oculomotor centers. Left undetermined is exactly how the copy is created, but it is plausible that the axons innervating thalamus from the superior colliculus are branches of those innervating oculomotor centers, which would fit the scheme of Figure 10.

Studies of various areas of cortex have described neurons that shift receptive fields prior to a saccade in just the manner predicted by a forward model of the impending saccade (40, 59, 111). Furthermore, such neurons are found at numerous hierarchical levels in visual cortex, being very rare in V1 and increasing with hierarchical level (111). Although the scheme in Figure 10B is hypothetical, it is hard to imagine plausible alternative routes for efference copy information to reach early visual areas.

As a final consideration of this topic, it is informative to view efference copies from an evolutionary perspective. A key point noted above is that efference copies were first defined in flies and fishes and appear to be present in all animals capable of complex movements. This indicates that efference copies must have evolved very early in our biological history. Thus, primitive vertebrates behaving mostly on the basis of spinal circuits would rely on efference copies as depicted in Figure 15. As brainstem supraspinal control centers evolved, a corresponding set of efference copy circuits must have co-evolved. This suggests an evolutionary hierarchy of efference copies culminating in those related to the latest evolutionary appearance of thalamocortical circuits and leading to corticofugal pathways that influence behavior; and pathways

that affect behavior, such as newly evolved layer 5 corticofugal pathways, should have efference copies related to them. We suggest that this evolutionary step resulted in efference copies such as those indicated in Figure 10. Evolution is like a pack rat: old neural circuits tend to remain and function even as newer ones emerge, leading to the evolution of new cortical circuits for behavior that operate by influencing older circuits in brainstem and spinal cord. This implies that efference copies for various movements are distributed widely in the central nervous system, which draws attention to a problem seldom noted: How does the brain deal with a hierarchical multitude of efference copies for any movement?

Role of Transthalamic Pathways

Embedded in this hypothesis is a specific role for the arrangement of direct and transthalamic corticocortical pathways. The idea is that the direct pathways provide the basic substrate for analysis of the environment (e.g., the visual world), while the transthalamic pathways inform higher cortical levels of possible motor actions (e.g., eye movements) to anticipate in further information processing.

However, this speculation should be seen as one possibility among others that need to be explored and may not be mutually exclusive. For instance, a different role is suggested by evidence cited above that transthalamic pathways play a role in the transfer of information between cortical areas rather than representing a different type of information (135). This relates to the flow of information across cortical hierarchies (43, 148, 167) and perhaps how cortical areas influence one another via transthalamic modulation. A related hypothesis is that an important feature of the parallel organization of direct and transthalamic corticocortical pathways is nonlinear summation between them. An observation of nonlinear summation would prove potentially important both to information transfer between areas as well as suggesting a mechanism whereby different areas can dynamically cooperate. Regarding the latter, much attention has recently been focused on the phenomenon of functional linking between different cortical areas, often via a process of phase-locked oscillations, thereby underlying a number of important cognitive functions (4, 47, 48, 52, 110, 120, 130, 139, 186). A key issue here relates to the circuitry subserving this. Thalamus is generally ignored as a participant in these processes, but we suggest otherwise and propose that cortical areas connected by both direct and transthalamic pathways that are active might favor some cortical pairings over others, which can be important both in information transfer as well as dynamic cooperation between cortical areas. In other words, the circuitry we described here can effectively determine which transthalamic signals get through, and thereby which areas are connected by activity in both circuits: with supralinear summation, this could enhance cooperation between areas, whereas sublinear summation could reduce it. A key in this scheme is the control of thalamic gating to determine which transthalamic pathways

are active. Much of the gating of these higher order thalamic relays can be done via layer 6 feedback circuits and/or the extra GABAergic inputs to higher order but not first order relays (both described earlier).

Relationship to Schizophrenia

There is a long history of cognitive defects associated with what we term higher order thalamic relays [e.g., (26, 105, 127)], and important clinical correlations exist. This seems especially true in schizophrenia. As determined by magnetic resonance imaging and postmortem anatomy in schizophrenic patients, of those thalamic areas studied, first order nuclei appear relatively normal but higher order nuclei (e.g., the medial dorsal nucleus and pulvinar) are shrunken with neuronal loss and reduced activity (14, 28, 32, 34, 39, 70, 108, 109, 117). This suggests that schizophrenia may specifically disrupt transthalamic circuits, which could account for many of the cognitive issues associated with schizophrenia, since such disruption would impair corticocortical communication. Also, as suggested by Figure 10, disruption of transthalamic pathways would likely lead to efference copy deficiencies. Indeed, this is precisely what is seen with schizophrenic patients: they have a variety of symptoms related to defective efference copy (44, 45, 126, 133, 158). Generally speaking, we suggest that this new concept involving transthalamic cortical pathways will prove critical in further understanding of cortical functioning in many areas of cognition, learning, memory, and attention, and also may prove a useful hypothetical framework against which to consider thalamic deficits in various clinical conditions such as schizophrenia.

Concluding Remarks

Challenges to the conventional view of thalamocortical processing

Figure 16 contrasts the conventional view of thalamocortical processing (Fig. 16A) with the alternate view proposed here (Fig. 16B). The conventional view, typically seen in textbook accounts [e.g., Fig. 18-2 of (78) or Fig. 12.18 of (125)], can be summed up as follows (43): Information first passes through thalamus to reach cortex, an example being the relay of retinal information to visual cortex via the lateral geniculate nucleus. This information is then processed through a hierarchical series of sensory, sensorimotor, and finally motor areas until a top, executive level is reached. From this level a message is sent subcortically to brainstem or spinal motor regions to change or initiate some behavior. Finally, at some abstractly considered position near the end of this circuit, an efference copy message is supplied. This represents a sensorimotor circuit based on a chain of glutamatergic neurons that defines a functional input/output circuit involved in the transmission and processing of information leading to a behavioral result. Challenges to this view follow.

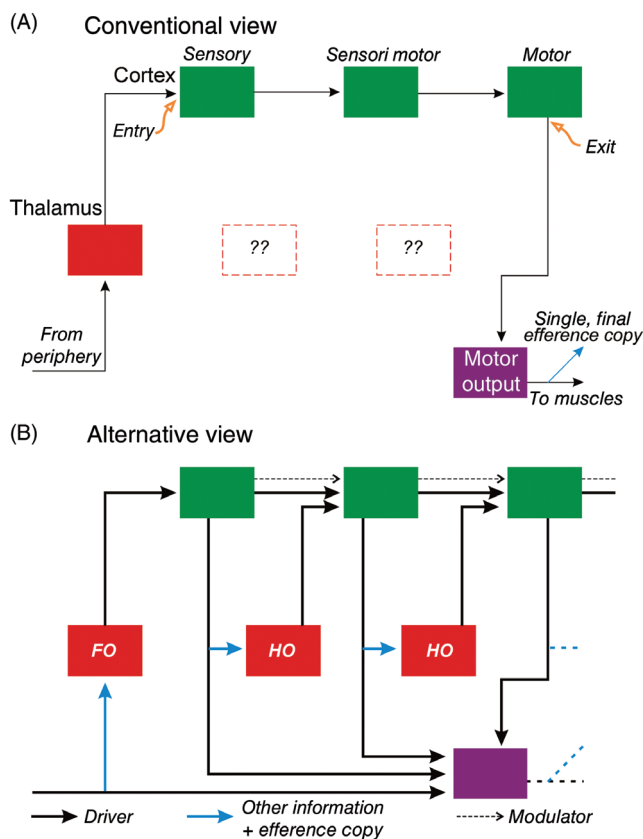

Figure 16 Comparison of conventional view (A) with the alternative view proposed here (B). The question marks in A indicate higher order thalamic relays, for which no specific function is suggested in this scheme. Further details in text. Abbreviations: FO, first order; HO, higher order.

Drivers and modulators. The conventional view of Figure 16A operates on an implicit assumption that circuits can be evaluated by identifying the glutamatergic elements, leaving out pathways involving other transmitter systems such as cholinergic, noradrenergic, GABAergic, etc., and treating the glutamatergic elements as if they were homogeneous and functioned in some sort of anatomical democracy. The larger the pathway or input, the more important it is in circuit functioning. By this strategy, we would completely misdiagnose circuitry of the lateral geniculate nucleus, in which of the two main glutamatergic inputs, the cortical feedback from layer 6 is numerically larger than the retinal input by roughly an order of magnitude (42, 168): we would conclude that the cortical input drives the geniculate relay cells, while the numerically small retinal input has some vague, subtle or trivial function. Only with the added information from receptive field physiology and synaptic properties do we avoid this mistake.

Nonetheless, this strategy, of determining the anatomical size of a projection, is typically used to determine hierarchical relationships between cortical areas. These are based on direct connections, which are all glutamatergic, and the only consideration to determine functioning is the size and laminar relationships of the connections (27, 98, 137). However,

recent physiology indicates that many of the direct corticocortical connections are modulators, like the cortical input to the lateral geniculate nucleus (29,35), and thus many connections assumed to be information bearing between areas are likely to be modulatory instead. The hierarchies established for cortical processing, it is argued here, should be reconsidered after identifying the subset of connections that are drivers.

First and higher order relays. Note that the scheme of Figure 16A has no role for most of thalamus that is referred to here as higher order. That is, in the conventional scheme, once information is relayed to cortex, that information is processed strictly within cortex until some final, executive stage is reached. However, the realization that higher order thalamic relays exist and that they play a major but as yet incompletely defined role in cortical processing (Fig. 16B) leads to a major revision of the conventional view.

Sensory versus motor cortex. The conventional scheme of Figure 16A has single entry and exit points for cortical processing with much neuronal processing and time intervening. However, this seems unlikely in the context of what we think we know about the evolution of sensorimotor systems. That is, the notion that sensorimotor processing could involve so many steps (and so much time) as suggested by Figure 16A before a behavioral response results from a new sensory message seems implausible: any time a new sensory receptor or peripheral sensory process evolves, it will have no survival value if it lacks a fairly immediate motor output. In this sense, the scheme of Figure 16B seems more likely, with early sensory inputs having a relatively immediate connection to motor outputs.

Another important difference between the schemes is that Figure 16A shows a clear difference between sensory cortex, which receives new subcortical sensory information but has no subcortical (or motor) outputs, and motor cortex, which receives no new subcortical information but does produce motor outputs. As Figure 16B suggests, every cortical area so far studied in this context has both input from thalamus as well as a layer 5 output that innervates subcortical motor structures [reviewed in (147)]. Thus, the common distinction between sensory and motor cortex seems misleading: the differences are more quantitative than qualitative, even the terminology (i.e., “sensory cortex” vs. “motor cortex”) should be reconsidered.

Efference copies. Most accounts of efference copies place them vaguely and abstractly at the end of complex processing streams, although exceptions to this are noted above (187), and there is a single efference copy for any impending behavioral event. Thus the scheme in Figure 16A has no efference copies associated with corticofugal messages. This is an obvious difference with the alternative scheme of Figure 16B. Note in this schema that the message for efference copies can also be interpreted as other information (e.g., sensory), as noted above for the schema of Figure 15B. Furthermore, given the point emphasized above, that, for cortex to be relevant, it must produce motor messages via layer 5 outputs, it follows that these outputs should be paired with efference

copies, because, as argued above, motor messages unaccompanied by efference copies can lead to ambiguities between self-generated actions and environmental events.

Questions arising

The challenge to conventional views of thalamocortical interactions as summarized in Figure 16 offers new perspectives, but it also raises a number of new questions that could provide an impetus for new research directions. These questions are simply listed below.

- *How commonly are direct corticocortical connections paralleled by transthalamic ones?* A limited number of examples exist for both circuits being arranged in parallel, mostly in sensory pathways. However, the possibility that direct pathways or transthalamic pathways commonly exist on their own needs further study.
- *How does the information carried by each route differ?* One possibility (among others) is that the direct pathways provide the basic processing of information, and transthalamic pathways update higher areas in the cortical hierarchy with efference copies. However, this is merely a plausible hypothesis at present, and it and other possibilities need testing.
- *What is the significance of the convergence of direct and transthalamic pathways?* These pathways converge onto layer 4 cells, and possibly others, in the target cortical area (29, 35, 89, 141). This leads to the possibility of nonlinear summation of responses to these two inputs, which could play a role in functional linking of cortical areas, although many other possibilities can also be imagined. Note that this idea and that noted in the previous bullet point are not mutually exclusive.
- *Why is one of the pathways relayed through thalamus?* It is important to realize that layer 5 projecting axons with branches could directly innervate higher cortical areas without relaying through thalamus, so features of thalamic processing must be critical for this information route. Possibilities include gating (since this route can be blocked by strongly inhibiting relay cells) and using the burst/tonic firing modes, in the sense that new information traveling in these pathways could be initiated with burst firing as a “wake-up call” to the higher cortical area (141).
- *Are transthalamic pathways strictly feedforward?* The only transthalamic circuits so far identified seem to be organized in a feedforward manner to transmit information up a cortical hierarchy. Perhaps other transthalamic arrangements exist, such as feedback circuits allowing higher order cortical areas to affect lower ones.
- *What is the significance of the branching driver input to thalamus?* It is an anatomical fact that many, most, or

perhaps all driving inputs to thalamus branch with extensive extrathalamic targets. It also follows that the message sent for relay through thalamus is commonly shared with multiple other subcortical centers. The idea that this may be related to efference copy mechanisms is an attempt to make sense of the anatomy due to the observation that many of the extrathalamic targets of these branching axons seem to be motor centers. Again, however, this remains a hypothesis only.

- *If an evolutionary hierarchy of efference copies exists, culminating in those related to thalamocortical circuits, how does this multilevel representation of efference copies function to produce effective behavioral correction for anticipated self-motion?* This seems to be an unrecognized conundrum for the brain to solve, because with the multiplicity of efference copy messages generated, the possibility that some may not relate to actual movements exists.

Conclusions

Three fundamental and novel ideas have been forwarded here. First, glutamatergic pathways in thalamus and cortex are not homogeneous but instead fall into driver and modulator classes. Because glutamatergic driver inputs seem to carry information, whereas the glutamatergic modulators serve to topographically affect the processing of driver inputs, it is important in parsing circuits to distinguish these. Second, the driver input to many thalamic nuclei, comprising most of thalamus by volume, arises from layer 5 of cortex. We call those nuclei receiving a subcortical driver input first order, and those receiving a cortical driver input higher order. The higher order nuclei are parts of feedforward cortico-thalamocortical, transthalamic circuits, meaning that most of thalamus is involved in corticocortical communication. Third, driver inputs to thalamus, both first and higher order, commonly involve branched axons that also innervate subcortical sites identified as motor centers. This leads to speculation that these driver inputs may act as efference copies.

Acknowledgments

This work was supported by Grants DC008794, EY022338, and NS094184 from the National Institutes of Health.

References

1. Ahmed B, Anderson JC, Douglas RJ, Martin KAC, Nelson JC. Polynuclear innervation of spiny stellate neurons in cat visual cortex. *J Comp Neurol* 341: 39-49, 1994.
2. Alitto HJ, Usrey WM. Corticothalamic feedback and sensory processing. *Curr Opin Neurobiol* 13: 440-445, 2003.
3. Allen NJ. Astrocyte regulation of synaptic behavior. *Annu Rev Cell Dev Biol* 30: 439-463, 2014.
4. Andersen RA, Cui H. Intention, action planning, and decision making in parietal-frontal circuits. *Neuron* 63: 568-583, 2009.

5. Andolina IM, Jones HE, Sillito AM. Effects of cortical feedback on the spatial properties of relay cells in the lateral geniculate nucleus. *J Neurophysiol* 109: 889-899, 2013.
6. Arcelli P, Frassoni C, Regondi MC, De Biasi S, Spreafico R. GABAergic neurons in mammalian thalamus: A marker of thalamic complexity? *Brain Res Bull* 42: 27-37, 1997.
7. Baker FH, Malpeli JG. Effects of cryogenic blockade of visual cortex on the responses of lateral geniculate neurons in the monkey. *Exp Brain Res* 29: 433-444, 1977.
8. Bender DB. Visual activation of neurons in the primate pulvinar depends on cortex but not colliculus. *Brain Res* 279: 258-261, 1983.
9. Berman RA, Wurtz RH. Functional identification of a pulvinar path from superior colliculus to cortical area MT. *J Neurosci* 30: 6342-6354, 2010.
10. Bickford ME, Zhou N, Krahe TE, Govindaiah G, Guido W. Retinal and tectal "driver-like" inputs converge in the shell of the mouse dorsal lateral geniculate nucleus. *J Neurosci* 35: 10523-10534, 2015.
11. Bokor H, Frere SGA, Eyre MD, Slezia A, Ulbert I, Luthi A, Acsády L. Selective GABAergic control of higher-order thalamic relays. *Neuron* 45: 929-940, 2005.
12. Bourassa J, Deschênes M. Corticothalamic projections from the primary visual cortex in rats: A single fiber study using biocytin as an anterograde tracer. *Neurosci* 66: 253-263, 1995.
13. Bourassa J, Pinault D, Deschênes M. Corticothalamic projections from the cortical barrel field to the somatosensory thalamus in rats: A single-fibre study using biocytin as an anterograde tracer. *Eur J Neurosci* 7: 19-30, 1995.
14. Brickman AM, Buchsbaum MS, Shihabuddin L, Byne W, Newmark RE, Brand J, Ahmed S, Mitelman SA, Hazlett EA. Thalamus size and outcome in schizophrenia. *Schizophr Res* 71: 473-484, 2004.
15. Briggs F, Kiley CW, Callaway EM, Usrey WM. Morphological substrates for parallel streams of corticogeniculate feedback originating in both V1 and V2 of the macaque monkey. *Neuron* 90: 388-399, 2016.
16. Briggs F, Mangun GR, Usrey WM. Attention enhances synaptic efficacy and the signal-to-noise ratio in neural circuits. *Nature* 499: 476-480, 2013.
17. Briggs F, Usrey WM. Parallel processing in the corticogeniculate pathway of the macaque monkey. *Neuron* 62: 135-146, 2009.
18. Bull MS, Berkley KJ. Differences in the neurones that project from the dorsal column nuclei to the diencephalon, pretectum, and the tectum in the cat. *Somatosens Res* 1: 281-300, 1984.
19. Cajal SR. *Histologie du Système Nerveux de l'Homme et des Vertébrés*. Paris: Maloine, 1911.
20. Carandini M. Receptive fields and suppressive fields in the early visual system. In: Gazzaniga MS, editor. *The Cognitive Neurosciences*. Cambridge, MA: MIT Press, 2004. p. 313-326.
21. Casanova C. Response properties of neurons in area 17 projecting to the striate-recipient zone of the cat's lateralis posterior-pulvinar complex: Comparison with cortico-tectal cells. *Exp Brain Res* 96: 247-259, 1993.
22. Catterall WA. Ion channel voltage sensors: Structure, function, and pathophysiology. *Neuron* 67: 915-928, 2010.
23. Chalupa LM, Anchel H, Lindsley DB. Visual input to the pulvinar via lateral geniculate, superior colliculus and visual cortex in the cat. *Exp Neurol* 36: 449-462, 1972.
24. Chalupa LM, Thompson ID. Retinal ganglion cell projections to the superior colliculus of the hamster demonstrated by the horseradish peroxidase technique. *Neurosci Lett* 19: 13-19, 1980.
25. Chance FS, Abbott LF, Reyes A. Gain modulation from background synaptic input. *Neuron* 35: 773-782, 2002.
26. Chauveau F, Celerier A, Ognard R, Pierard C, Beracochea D. Effects of ibotenic acid lesions of the mediadorsal thalamus on memory: Relationship with emotional processes in mice. *Behav Brain Res* 156: 215-223, 2005.
27. Coogan TA, Burkhalter A. Hierarchical organization of areas in rat visual cortex. *J Neurosci* 13: 3749-3772, 1993.
28. Coscia DM, Narr KL, Robinson DG, Hamilton LS, Sevy S, Burdick KE, GunduzBruce H, McCormack J, Bilder RM, Szeszko PR. Volumetric and shape analysis of the thalamus in first-episode schizophrenia. *Hum Brain Mapp* 30: 1236-1245, 2009.
29. Covic EN, Sherman SM. Synaptic properties of connections between the primary and secondary auditory cortices in mice. *Cereb Cortex* 21: 2425-2441, 2011.
30. Cox CL, Sherman SM. Control of dendritic outputs of inhibitory interneurons in the lateral geniculate nucleus. *Neuron* 27: 597-610, 2000.
31. Crandall SR, Cruikshank SJ, Connors BW. A corticothalamic switch: Controlling the thalamus with dynamic synapses. *Neuron* 86: 768-782, 2015.
32. Cronenwett WJ, Csernansky J. Thalamic pathology in schizophrenia. *Curr Top Behav Neurosci* 4: 509-528, 2010.
33. Dankowski A, Bickford ME. Inhibitory circuitry involving Y cells and Y retinal terminals in the C laminae of the cat dorsal lateral geniculate nucleus. *J Comp Neurol* 460: 368-379, 2003.
34. Danos P, Baumann B, Kramer A, Bernstein HG, Stauch R, Krell D, Falkai P, Bogerts B. Volumes of association thalamic nuclei in schizophrenia: A postmortem study. *Schizophr Res* 60: 141-155, 2003.
35. DePasquale R, Sherman SM. Synaptic properties of corticocortical connections between the primary and secondary visual cortical areas in the mouse. *J Neurosci* 31: 16494-16506, 2011.
36. Deschênes M, Bourassa J, Pinault D. Corticothalamic projections from layer V cells in rat are collaterals of long-range corticofugal axons. *Brain Res* 664: 215-219, 1994.
37. Diamond ME, Armstrong-James M, Ebner FF. Somatic sensory responses in the rostral sector of the posterior group (POM) and in the ventral posterior medial nucleus (VPM) of the rat thalamus. *J Comp Neurol* 318: 462-476, 1992.
38. Donishi T, Kimura A, Imbe H, Yokoi I, Kaneoke Y. Sub-threshold cross-modal sensory interaction in the thalamus: Lemnisc auditory response in the medial geniculate nucleus is modulated by somatosensory stimulation. *Neurosci* 174: 200-215, 2011.
39. DorphPeterson KA, Caric D, Saghati R, Zhang W, Sampson AR, Lewis DA. Volume and neuron number of the lateral geniculate nucleus in schizophrenia and mood disorders. *Acta Neuropathol* 117: 369-384, 2009.
40. Duhamel J-R, Colby CL, Goldberg ME. The updating of the representation of visual space in parietal cortex by intended eye movements. *Science* 255: 90-92, 1992.
41. Eriřir A, Van Horn SC, Bickford ME, Sherman SM. Immunocytochemistry and distribution of parabrachial terminals in the lateral geniculate nucleus of the cat: A comparison with corticogeniculate terminals. *J Comp Neurol* 377: 535-549, 1997.
42. Eriřir A, Van Horn SC, Sherman SM. Relative numbers of cortical and brainstem inputs to the lateral geniculate nucleus. *Proc Natl Acad Sci U S A* 94: 1517-1520, 1997.
43. Felleman DJ, Van Essen DC. Distributed hierarchical processing in the primate cerebral cortex. *Cereb Cortex* 1: 1-47, 1991.
44. Ford JM, Palzes VA, Roach BJ, Mathalon DH. Did I do that? Abnormal predictive processes in schizophrenia when button pressing to deliver a tone. *Schizophr Bull* 40: 804-812, 2014.
45. Ford JM, Roach BJ, Faustman WO, Mathalon DH. Out-of-synch and out-of-sorts: Dysfunction of motor-sensory communication in schizophrenia. *Biol Psychiatry* 63: 736-743, 2008.
46. Friedlander MJ, Lin C-S, Stanford LR, Sherman SM. Morphology of functionally identified neurons in lateral geniculate nucleus of the cat. *J Neurophysiol* 46: 80-129, 1981.
47. Fries P. Neuronal gamma-band synchronization as a fundamental process in cortical computation. *Annu Rev Neurosci* 32: 209-224, 2009.
48. Fries P, Nikolic D, Singer W. The gamma cycle. *Trends Neurosci* 30: 309-316, 2007.
49. Geisler EE, Langsetmo A, Spear PD. Influence of the cortico-geniculate pathway on response properties of cat lateral geniculate neurons. *Brain Res* 208: 409-415, 1981.
50. Govindaiah, Cox CL. Synaptic activation of metabotropic glutamate receptors regulates dendritic outputs of thalamic interneurons. *Neuron* 41: 611-623, 2004.
51. Govindaiah G, Wang T, Gillette MU, Cox CL. Activity-dependent regulation of retinogeniculate signaling by metabotropic glutamate receptors. *J Neurosci* 32: 12820-12831, 2012.
52. Gregoriou GG, Gotts SJ, Zhou H, Desimone R. High-frequency, long-range coupling between prefrontal and visual cortex during attention. *Science* 324: 1207-1210, 2009.
53. Groh A, Bokor H, Mease RA, Plattner VM, Hangya B, Stroth A, Deschênes M, Acsády L. Convergence of cortical and sensory driver inputs on single thalamocortical cells. *Cereb Cortex* 24: 3167-3179, 2014.
54. Groh A, Bokor H, Mease RA, Plattner VM, Hangya B, Stroth A, Deschênes M, Acsády L. Convergence of cortical and sensory driver inputs on single thalamocortical cells. *Cereb Cortex* 24: 3167-3179, 2014.
55. Guillery RW. Degeneration in the hypothalamic connexions of the albino rat. *J Anat (Lond)* 91: 91-115, 1957.
56. Guillery RW. Anatomical evidence concerning the role of the thalamus in corticocortical communication: A brief review. *J Anat* 187: 583-592, 1995.
57. Guillery RW, Sherman SM. Branched thalamic afferents: What are the messages that they relay to cortex? *Brain Res Brain Res Rev* 66: 205-219, 2011.
58. Gulcebi MI, Ketenci S, Linke R, Hacıoglu H, Yanali H, Veliskova J, Moshe SL, Onat F, Cavdar S. Topographical connections of the substantia nigra pars reticulata to higher-order thalamic nuclei in the rat. *Brain Res Bull* 87: 312-318, 2012.
59. Hall NJ, Colby CL. Remapping for visual stability. *Philos Trans R Soc Lond B Biol Sci* 366: 528-539, 2011.
60. Hamos JE, Van Horn SC, Raczkowski D, Sherman SM. Synaptic circuits involving an individual retinogeniculate axon in the cat. *J Comp Neurol* 259: 165-192, 1987.

61. Hamos JE, Van Horn SC, Raczkowski D, Uhrlich DJ, Sherman SM. Synaptic connectivity of a local circuit neurone in lateral geniculate nucleus of the cat. *Nature* 317: 618-621, 1985.
62. Helmholtz H. *Handbuch der Physiologischen Optik Volume 3*. Leipzig: Voss, 1866.
63. Hirsch JA, Wang X, Sommer FT, Martinez LM. How inhibitory circuits in the thalamus serve vision. *Annu Rev Neurosci* 38: 309-329, 2015.
64. Hu B. Functional organization of lemniscal and nonlemniscal auditory thalamus. *Exp Brain Res* 153: 543-549, 2003.
65. Hubel DH, Wiesel TN. Brain mechanisms of vision. *Sci Am* 241: 150-162, 1979.
66. Huguenard JR, McCormick DA. *Electrophysiology of the Neuron*. New York: Oxford University Press, 1994.
67. Isu N, Sakuma A, Kitahara M, Watanabe S, Uchino Y. Extracellular recording of vestibulo-thalamic neurons projecting to the spinal cord in the cat. *Neurosci Lett* 104: 25-30, 1989.
68. Jahnsen H, Llinás R. Electrophysiological properties of guinea-pig thalamic neurones: An *in vitro* study. *J Physiol (Lond)* 349: 205-226, 1984.
69. Jahnsen H, Llinás R. Ionic basis for the electroresponsiveness and oscillatory properties of guinea-pig thalamic neurones *in vitro*. *J Physiol (Lond)* 349: 227-247, 1984.
70. Janssen J, Aleman-Gomez Y, Reig S, Schnack HG, Parellada M, Graell M, Moreno C, Moreno D, Mateos-Perez JM, Udias JM, Arango C, Desco M. Regional specificity of thalamic volume deficits in male adolescents with early-onset psychosis. *Br J Psychiatry* 200: 30-36, 2012.
71. Jones EG. A new view of specific and nonspecific thalamocortical connections. *Adv Neurol* 77: 49-71, 1998.
72. Jones EG. Viewpoint: The core and matrix of thalamic organization. *Neurosci* 85: 331-345, 1998.
73. Jones EG. The thalamic matrix and thalamocortical synchrony. *Trends in Neurosci* 24: 595-601, 2001.
74. Jones EG. Thalamic circuitry and thalamocortical synchrony. *Philos Trans R Soc Lond [Biol]* 357: 1659-1673, 2002.
75. Jones EG. *The Thalamus: Second Edition*. Cambridge, U.K.: Cambridge University Press, 2007.
76. Jones EG. Synchrony in the interconnected circuitry of the thalamus and cerebral cortex. *Ann N Y Acad Sci* 1157: 10-23, 2009.
77. Kalil RE, Chase R. Corticofugal influence on activity of lateral geniculate neurons in the cat. *J Neurophysiol* 33: 459-474, 1970.
78. Kandel ER, Schwartz JH, Jessell TM. *Principles of Neural Science*. New York: McGraw Hill, 2000.
79. Kelly LR, Li J, Carden WB, Bickford ME. Ultrastructure and synaptic targets of tectothalamic terminals in the cat lateral posterior nucleus. *J Comp Neurol* 464: 472-486, 2003.
80. Kita T, Kita H. The subthalamic nucleus is one of multiple innervation sites for long-range corticofugal axons: A single-axon tracing study in the rat. *J Neurosci* 32: 5990-5999, 2012.
81. Kölliker A. *Handbuch der Gerbelehre des Menschen. Nervensystemen des Menschen und der Tiere*. Leipzig: Engelmann, 1896.
82. Kultas-Ilinsky K, Ilinsky A, Young PA, Smith KR. Ultrastructure of degenerating cerebellothalamic terminals in the ventral medial nucleus of the cat. *Exp Brain Res* 38: 125-135, 1980.
83. Kuramoto E, Fujiyama F, Nakamura KC, Tanaka Y, Hioki H, Kaneko T. Complementary distribution of glutamatergic cerebellar and GABAergic basal ganglia afferents to the rat motor thalamic nuclei. *Eur J Neurosci* 33: 95-109, 2011.
84. Kuramoto E, Ohno S, Furuta T, Unzai T, Tanaka YR, Hioki H, Kaneko T. Ventral medial nucleus neurons send thalamocortical afferents more widely and more preferentially to layer 1 than neurons of the ventral anterior-ventral lateral nuclear complex in the rat. *Cereb Cortex* 25: 221-235, 2015.
85. Lam YW, Sherman SM. Functional organization of the somatosensory cortical layer 6 feedback to the thalamus. *Cereb Cortex* 20: 13-24, 2010.
86. Lam YW, Sherman SM. Activation of both Group I and Group II metabotropic glutamatergic receptors suppress retinogeniculate transmission. *Neurosci* 242: 78-84, 2013.
87. Lavallée P, Urbain N, Dufresne C, Bokor H, Acsády L, Deschênes M. Feedforward inhibitory control of sensory information in higher-order thalamic nuclei. *J Neurosci* 25: 7489-7498, 2005.
88. Lee CC, Kishan AU, Winer JA. Wiring of divergent networks in the central auditory system. *Front Neuroanat* 5: 46, 2011.
89. Lee CC, Sherman SM. Synaptic properties of thalamic and intracortical inputs to layer 4 of the first- and higher-order cortical areas in the auditory and somatosensory systems. *J Neurophysiol* 100: 317-326, 2008.
90. Lee CC, Sherman SM. Glutamatergic inhibition in sensory neocortex. *Cereb Cortex* 19: 2281-2289, 2009.
91. Lee CC, Sherman SM. Topography and physiology of ascending streams in the auditory tectothalamic pathway. *Proc Nat Acad Sci Usa* 107: 372-377, 2010.
92. Lee CC, Sherman SM. Intrinsic modulators of auditory thalamocortical transmission. *Hear Res* 287: 43-50, 2012.
93. Lesica NA, Weng C, Jin J, Yeh CI, Alonso JM, Stanley GB. Dynamic encoding of natural luminance sequences by LGN bursts. *Plos Biol* 4: e209, 2006.
94. Levitan IB, Kaczmarek LK. *The Neuron: Cell and Molecular Biology*. New York: Oxford University Press, 2002.
95. Linden R, Perry VH. Massive retinotectal projection in rats. *Brain Res* 272: 145-149, 1983.
96. Llano DA, Sherman SM. Evidence for nonreciprocal organization of the mouse auditory thalamocortical-corticothalamic projection systems. *J Comp Neurol* 507: 1209-1227, 2008.
97. Lujan R, Nusser Z, Roberts JD, Shigemoto R, Somogyi P. Perisynaptic location of metabotropic glutamate receptors mGluR1 and mGluR5 on dendrites and dendritic spines in the rat hippocampus. *Eur J Neurosci* 8: 1488-1500, 1996.
98. Markov NT, Vezoli J, Chameau P, Falchier A, Quilodran R, Huisoud C, Lamy C, Misery P, Giroud P, Ullman S, Barone P, Dehay C, Knoblauch K, Kennedy H. Anatomy of hierarchy: Feedforward and feedback pathways in macaque visual cortex. *J Comp Neurol* 522: 225-259, 2014.
99. Matsuo S, Hasogai M, Nakao S. Ascending projections of posterior canal activated excitatory and inhibitory secondary vestibular neurons to the mesodiencephalon in cats. *Exp Brain Res* 100: 7-17, 1994.
100. McAlonan K, Cavanaugh J, Wurtz RH. Guarding the gateway to cortex with attention in visual thalamus. *Nature* 2008.
101. McClurkin JW, Marrocco RT. Visual cortical input alters spatial tuning in monkey lateral geniculate nucleus cells. *J Physiol (Lond)* 348: 135-152, 1984.
102. McClurkin JW, Optican LM, Richmond BJ. Cortical feedback increases visual information transmitted by monkey parvocellular lateral geniculate nucleus neurons. *Visual Neurosci* 11: 601-617, 1994.
103. McCreary RA, Bishop GA, Kitai ST. Morphological and electrophysiological characteristics of projection neurons in the nucleus interpositus of the cat cerebellum. *J Comp Neurol* 181: 397-419, 1978.
104. McFarland NR, Haber SN. Thalamic relay nuclei of the basal ganglia form both reciprocal and nonreciprocal cortical connections, linking multiple frontal cortical areas. *J Neurosci* 22: 8117-8132, 2002.
105. Means LW, Harrell TH, Mayo ES, Alexander GB. Effects of dorso-medial thalamic lesions on spontaneous alternation, maze, activity and runway performance in the rat. *Physiol Behav* 12: 973-979, 1974.
106. Mease RA, Krieger P, Groh A. Cortical control of adaptation and sensory relay mode in the thalamus. *Proc Natl Acad Sci U S A* 2014.
107. Merabet L, Desautels A, Minville K, Casanova C. Motion integration in a thalamic visual nucleus. *Nature* 396: 265-268, 1998.
108. Mitelman SA, Brickman AM, Shihabuddin L, Newmark R, Chu KW, Buchsbaum MS. Correlations between MRI-assessed volumes of the thalamus and cortical Brodmann's areas in schizophrenia. *Schizophr Res* 75: 265-281, 2005.
109. Mitelman SA, Byne W, Kemether EM, Hazlett EA, Buchsbaum MS. Metabolic disconnection between the mediodorsal nucleus of the thalamus and cortical Brodmann's areas of the left hemisphere in schizophrenia. *Am J Psychiatry* 162: 1733-1735, 2005.
110. Moore T, Armstrong KM. Selective gating of visual signals by microstimulation of frontal cortex. *Nature* 421: 370-373, 2003.
111. Nakamura K, Colby CL. Updating of the visual representation in monkey striate and extrastriate cortex during saccades. *Proc Natl Acad Sci U S A* 99: 4026-4031, 2002.
112. Nicoll RA, Malenka RC, Kauer JA. Functional comparison of neurotransmitter receptor subtypes in mammalian central nervous system. *Physiol Rev* 70: 513-565, 1990.
113. Ojima H. Terminal morphology and distribution of corticothalamic fibers originating from layers 5 and 6 of cat primary auditory cortex. *Cereb Cortex* 4: 646-663, 1994.
114. Ojima H, Murakami K. Triadic synaptic interactions of large corticothalamic terminals in non-lemniscal thalamic nuclei of the cat auditory system. *Hear Res* 274: 40-47, 2011.
115. Olsen SR, Bortone DS, Adesnik H, Scanziani M. Gain control by layer six in cortical circuits of vision. *Nature* 483: 47-52, 2012.
116. Ortuno T, Grieve KL, Cao R, Cudeiro J, Rivadulla C. Bursting thalamic responses in awake monkey contribute to visual detection and are modulated by corticofugal feedback. *Front Behav Neurosci* 8: 198, 2014.
117. Parnaudeau S, O'Neill PK, Bolkan SS, Ward RD, Abbas AI, Roth BL, Balsam PD, Gordon JA, Kellendonk C. Inhibition of mediodorsal thalamus disrupts thalamofrontal connectivity and cognition. *Neuron* 77: 1151-1162, 2013.
118. Perea G, Yang A, Boyden ES, Sur M. Optogenetic astrocyte activation modulates response selectivity of visual cortex neurons in vivo. *Nat Commun* 5: 3262, 2014.
119. Pereira de Vasconcelos A, Cassel JC. The nonspecific thalamus: A place in a wedding bed for making memories last? *Neurosci Biobehav Rev* 54: 175-196, 2015.

120. Pesaran B, Nelson MJ, Andersen RA. Free choice activates a decision circuit between frontal and parietal cortex. *Nature* 453: 406-409, 2008.
121. Petrof I, Sherman SM. Synaptic properties of the mammillary and cortical afferents to the anterodorsal thalamic nucleus in the mouse. *J Neurosci* 29: 7815-7819, 2009.
122. Petrof I, Viaene AN, Sherman SM. Synaptic properties of the lemniscal and paralemniscal somatosensory inputs to the mouse thalamus. *Soc Neurosci*, 2012.
123. Petrof I, Viaene AN, Sherman SM. Two populations of corticothalamic and interareal corticocortical cells in the subgranular layers of the mouse primary sensory cortices. *J Comp Neurol* 520: 1678-1686, 2012.
124. Purushothaman G, Marion R, Li K, Casagrande VA. Gating and control of primary visual cortex by pulvinar. *Nat Neurosci* 15: 905-912, 2012.
125. Purves D, Augustine GJ, Fitzpatrick D, Hall WC, Lamantia A-S, White LE. *Neuroscience*. Sunderland, MA: Sinauer, 2012.
126. Pynn LK, DeSouza JF. The function of efference copy signals: Implications for symptoms of schizophrenia. *Vision Res* 76: 124-133, 2013.
127. Rafal RD, Posner MI. Deficits in human visual spatial attention following thalamic lesions. *Proc Natl Acad Sci U S A* 84: 7349-7353, 1987.
128. Ramcharan EJ, Gnadt JW, Sherman SM. Higher-order thalamic relays burst more than first-order relays. *Proc Natl Acad Sci U S A* 102: 12236-12241, 2005.
129. Reichova I, Sherman SM. Somatosensory corticothalamic projections: Distinguishing drivers from modulators. *J Neurophysiol* 92: 2185-2197, 2004.
130. Reynolds JH, Chelazzi L, Desimone R. Competitive mechanisms subserve attention in macaque areas V2 and V4. *J Neurosci* 19: 1736-1753, 1999.
131. Richard D, Giovanni Y, Kitsikis A, Buser P. A study of geniculate unit activity during cryogenic blockade of the primary visual cortex in the cat. *Exp Brain Res* 22: 235-242, 1975.
132. Rockland KS. Convergence and branching patterns of round, type 2 corticopulvinar axons. *J Comp Neurol* 390: 515-536, 1998.
133. Rosler L, Rolfs M, van der Stigchel S, Neggers SF, Cahn W, Kahn RS, Thakkar KN. Failure to use corollary discharge to remap visual target locations is associated with psychotic symptom severity in schizophrenia. *J Neurophysiol* 114: 1129-1136, 2015.
134. Roth MM, Dahmen JC, Muir DR, Imhof F, Martini FJ, Hofer SB. Thalamic nuclei convey diverse contextual information to layer 1 of visual cortex. *Nat Neurosci* 19: 299-307, 2016.
135. Saalmann YB, Pinsk MA, Wang L, Li X, Kastner S. The pulvinar regulates information transmission between cortical areas based on attention demands. *Science* 337: 753-756, 2012.
136. Sakai ST, Inase M, Tanji J. Comparison of cerebellothalamic and pallidothalamic projections in the monkey (*Macaca fuscata*): A double anterograde labeling study. *J Comp Neurol* 368: 215-228, 1996.
137. Scannell JW, Blakemore C, Young MP. Analysis of connectivity in the cat cerebral cortex. *J Neurosci* 15: 1463-1483, 1995.
138. Schmielau F, Singer W. The role of visual cortex for binocular interactions in the cat lateral geniculate nucleus. *Brain Res* 120: 354-361, 1977.
139. Seidemann E, Zohary E, Newsome WT. Temporal gating of neural signals during performance of a visual discrimination task. *Nature* 394: 72-75, 1998.
140. Sherman SM. Functional organization of the W-, X-, and Y-cell pathways in the cat: A review and hypothesis. In: Sprague JM, Epstein AN, editors. *Progress in Psychobiology and Physiological Psychology*, Vol. 11. Orlando: Academic Press, 1985, pp. 233-314.
141. Sherman SM. Tonic and burst firing: Dual modes of thalamocortical relay. *Trends in Neurosci* 24: 122-126, 2001.
142. Sherman SM. Interneurons and triadic circuitry of the thalamus. *Trends in Neurosci* 27: 670-675, 2004.
143. Sherman SM. The thalamus is more than just a relay. *Curr Opin Neurobiol* 17: 1-6, 2007.
144. Sherman SM. The function of metabotropic glutamate receptors in thalamus and cortex. *Neuroscientist* 20: 136-149, 2014.
145. Sherman SM. Thalamus plays a central role in ongoing cortical functioning. *Nat Neurosci* 19: 533-541, 2016.
146. Sherman SM, Guillery RW. On the actions that one nerve cell can have on another: Distinguishing "drivers" from "modulators". *Proc Natl Acad Sci U S A* 95: 7121-7126, 1998.
147. Sherman SM, Guillery RW. *Exploring the Thalamus and its Role in Cortical Function*. Cambridge, MA: MIT Press, 2006.
148. Sherman SM, Guillery RW. *Thalamocortical Processing: Understanding the Messages that Link the Cortex to the World*. Cambridge, MA: MIT Press, 2013.
149. Sherman SM, Koch C. Thalamus. In: Shepherd GM, editor. *The Synaptic Organization of the Brain*, Fourth Edition. New York: Oxford University Press, 1998, pp. 289-328.
150. Shinoda Y, Futami T, Mitoma H, Yokota J. Morphology of single neurones in the cerebello-rubrospinal system. *Behav Brain Res* 28: 59-64, 1988.
151. Sillito AM, Jones HE, Gerstein GL, West DC. Feature-linked synchronization of thalamic relay cell firing induced by feedback from the visual cortex. *Nature* 369: 479-482, 1994.
152. Sirota MG, Swadlow HA, Beloozerova IN. Three channels of corticothalamic communication during locomotion. *J Neurosci* 25: 5915-5925, 2005.
153. Smith GD, Cox CL, Sherman SM, Rinzel J. Fourier analysis of sinusoidally-driven thalamocortical relay neurons and a minimal integrate-and-fire-or-burst model. *J Neurophysiol* 83: 588-610, 2000.
154. Smith GD, Sherman SM. Detectability of excitatory versus inhibitory drive in an integrate-and-fire-or-burst thalamocortical relay neuron model. *J Neurosci* 22: 10242-10250, 2002.
155. Solomon SG, Peirce JW, Dhruv NT, Lennie P. Profound contrast adaptation early in the visual pathway. *Neuron* 42: 155-162, 2004.
156. Sommer MA, Wurtz RH. What the brain stem tells the frontal cortex. II. Role of the SC-MD-FEF pathway in corollary discharge. *J Neurophysiol* 91: 1403-1423, 2004.
157. Sommer MA, Wurtz RH. Brain circuits for the internal monitoring of movements. *Annu Rev Neurosci* 31: 317-338, 2008.
158. Spering M, Dias EC, Sanchez JL, Schutz AC, Javitt DC. Efference copy failure during smooth pursuit eye movements in schizophrenia. *J Neurosci* 33: 11779-11787, 2013.
159. Sperry RW. Neural basis of the spontaneous optokinetic response produced by visual inversion. *J Comp Neurol* 43: 482-489, 1950.
160. Stroh A, Adelsberger H, Groh A, Ruhlmann C, Fischer S, Schierloh A, Deisseroth K, Konnerth A. Making waves: Initiation and propagation of corticothalamic ca(2+) waves in vivo. *Neuron* 77: 1136-1150, 2013.
161. Swadlow HA, Gusev AG. The impact of "bursting" thalamic impulses at a neocortical synapse. *Nat Neurosci* 4: 402-408, 2001.
162. Swadlow HA, Gusev AG, Bezdudnaya T. Activation of a cortical column by a thalamocortical impulse. *J Neurosci* 22: 7766-7773, 2002.
163. Tamamaki N, Uhlrich DJ, Sherman SM. Morphology of physiologically identified retinal X and Y axons in the cat's thalamus and midbrain as revealed by intra-axonal injection of biocytin. *J Comp Neurol* 354: 583-607, 1994.
164. Theyel BB, Llano DA, Sherman SM. The corticothalamic circuit drives higher-order cortex in the mouse. *Nat Neurosci* 13: 84-88, 2010.
165. Tsumoto T, Suda K. Three groups of cortico-geniculate neurons and their distribution in binocular and monocular segments of cat striate cortex. *J Comp Neurol* 193: 223-236, 1980.
166. Uhlrich DJ, Cucchiari JB, Humphrey AL, Sherman SM. Morphology and axonal projection patterns of individual neurons in the cat perigeniculate nucleus. *J Neurophysiol* 65: 1528-1541, 1991.
167. Van Essen DC, Anderson CH, Felleman DJ. Information processing in the primate visual system: An integrated systems perspective. *Science* 255: 419-423, 1992.
168. Van Horn SC, Eriñir A, Sherman SM. The relative distribution of synapses in the A-laminae of the lateral geniculate nucleus of the cat. *J Comp Neurol* 416: 509-520, 2000.
169. Van Horn SC, Sherman SM. Fewer driver synapses in higher order than in first order thalamic relays. *Neurosci* 475: 406-415, 2007.
170. Vaney DI, Levick WR, Thibos LN. Rabbit retinal ganglion cells. *Exp Brain Res* 44: 27-33, 1981.
171. Varela C, Sherman SM. Differences in response to muscarinic agonists between first and higher order thalamic relays. *J Neurophysiol* 98: 3538-3547, 2007.
172. Varela C, Sherman SM. Differences in response to serotonergic activation between first and higher order thalamic nuclei. *Cereb Cortex* 19: 1776-1786, 2008.
173. Veinante P, Jacquin MF, Deschênes M. Thalamic projections from the whisker sensitive regions of the spinal trigeminal complex in the rat. *J Comp Neurol* 420: 233-243, 2000.
174. Veinante P, Lavallée P, Deschênes M. Corticothalamic projections from layer 5 of the vibrissal barrel cortex in the rat. *J Comp Neurol* 424: 197-204, 2000.
175. Vertes RP. Major diencephalic inputs to the hippocampus: Supramammillary nucleus and nucleus reuniens. Circuitry and function. *Prog Brain Res* 219: 121-144, 2015.
176. Vertes RP, Linley SB, Hoover WB. Limbic circuitry of the midline thalamus. *Neurosci Biobehav Rev* 54: 89-107, 2015.
177. Viaene AN, Petrof I, Sherman SM. Properties of the thalamic projection from the posterior medial nucleus to primary and secondary somatosensory cortices in the mouse. *Proc Natl Acad Sci Usa* 108: 18156-18161, 2011.
178. Viaene AN, Petrof I, Sherman SM. Activation requirements for metabotropic glutamate receptors. *Neurosci Lett* 541: 67-72, 2013.
179. von Holst E, Mittelstaedt H. The reafference principle. Interaction between the central nervous system and the periphery. In: Translated by Robert Martin, editor. *Selected Papers of Erich von Holst: The Behavioural Physiology of Animals and Man*. Coral Gables: University of Miami Press, 1950, p. 139-173.
180. Wang S, Eisenback MA, Bickford ME. Relative distribution of synapses in the pulvinar nucleus of the cat: Implications regarding the

- “driver/modulator” theory of thalamic function. *J Comp Neurol* 454: 482-494, 2002.
181. Wenstrup JJ. The tectothalamic system. In: Winer JA, Schreiner CE, editors. *The Inferior Colliculus*. New York: Springer, 2005, pp. 200-230.
 182. Whitmire CJ, Millard DC, Stanley GB. Thalamic state control of cortical paired-pulse dynamics. *J Neurophysiol* 117: 163-177, 2016.
 183. Wilke M, Mueller KM, Leopold DA. Neural activity in the visual thalamus reflects perceptual suppression. *Proc Nat Acad Sci Usa* 106: 9465-9470, 2009.
 184. Wilson JR, Friedlander MJ, Sherman SM. Fine structural morphology of identified X- and Y-cells in the cat's lateral geniculate nucleus. *Proc Roy Soc Lond B* 221: 411-436, 1984.
 185. Wolpert DM, Flanagan JR. Motor learning. *Curr Biol* 20: R467-R472, 2010.
 186. Womelsdorf T, Fries P, Mitra PP, Desimone R. Gamma-band synchronization in visual cortex predicts speed of change detection. *Nature* 439: 733-736, 2006.
 187. Wurtz RH, Sommer MA. Identifying corollary discharges for movement in the primate brain. *Prog Brain Res* 144: 47-60, 2004.
 188. Xu XM, Bosking WH, White LE, Fitzpatrick D, Casagrande VA. Functional organization of visual cortex in the prosimian bushy baby revealed by optical imaging of intrinsic signals. *J Neurophysiol* 94: 2748-2762, 2005.
 189. Zhan XJ, Cox CL, Rinzel J, Sherman SM. Current clamp and modeling studies of low threshold calcium spikes in cells of the cat's lateral geniculate nucleus. *J Neurophysiol* 81: 2360-2373, 1999.
 190. Zhou H, Schafer RJ, Desimone R. Pulvinar-cortex interactions in vision and attention. *Neuron* 89: 209-220, 2016.